

MTL4600 range

Isolating interfaces

- **3-port isolation as standard**
- **Highest module/channel packing densities**
- **Low power dissipation**
- **Quick install and release mechanism**
- **Multi-channel I/O modules**
- **Broken line and earth-fault protection**

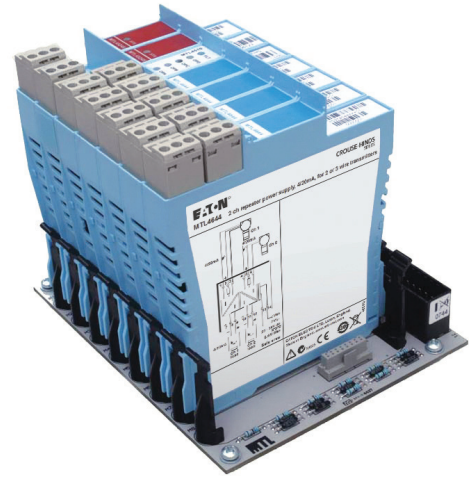

Isolation—protecting your system Designing your plant with good clean earth systems is not always possible. Poor ground conductivity, large process areas and heavy electrical machinery, all contribute to increased noise. This noise is induced or conducted into adjacent wiring, which in turn degrades the quality of the signals passing through the cables. Without isolation this noise is superimposed on the process signal causing a loss of accuracy, poor control and possibly failures or false trips.

Many control systems, PLCs and safety systems do not have full isolation between channels. In compact well defined plant layouts this is acceptable, but these are not always guaranteed. To avoid interference between channels, isolation is the solution.

The MTL4600 range of isolators offer reduced risk and greater protection to the system, with all the advantages of a common design approach for both IS and non-IS signals.

System Solutions

Building on the base of the MTL4500 range of solutions, the MTL4600 offers a high level of signal isolation for installations where multiple loops on a common connection are not desirable.

Signal isolation provides excellent protection against surges, common faults and noisy environments. It also eliminates the risk of earth loops between different areas of the plant, which, if not isolated, can cause significant errors or failures under fault conditions.

MTL4600 isolators are fully compatible with all existing backplanes used with MTL4500 range and many control systems. The form factor and signal types offer the user a common approach for both IS and non-IS signals.

The backplane mounting MTL4600 range is designed with system vendors in mind for "project-focussed" applications such as Distributed Control System (DCS), Emergency Shutdown Systems (ESD) and Fire and Gas monitoring (F&G).

The reduced power consumption and high efficiency enable high signal density to be achieved together with improved freedom in cabinet layout and design. Easy integration with the input/output assemblies of control or safety instrumentation systems not only simplifies project engineering but also reduces installation and maintenance costs.

A multiway connector to the backplane provides safe-area and power supply connections, while hazardous-area connections plug into the front of the module, simplifying installation and maintenance and reducing time, cost, and the risk of errors.

Line fault detection (LFD) facilities are provided across the range of I/O functions; on the switch/proximity detectors, the MTL4623 solenoid/ alarm drivers and the isolating drivers. Analogue input units such as the MTL4641 provide line fault detection by repeating o/c or s/c currents to the control system.

Status LEDs, configuration switches and ports are located on the top or side of individual modules, as appropriate, for easy access.

ISOLATOR FUNCTION SELECTOR

		Channels	Function
Digital Input			
MTL4604		1	switch/prox input, phase reversal + LFD
MTL4610		4	switch/prox input, solid-state output
MTL4611		1	switch/prox input, c/o relay output
MTL4613		2	switch/prox input, solid-state output
MTL4614		1	switch/prox input, relay + LFD alarm
MTL4614D		1	switch/prox input, dual output relay
MTL4616		2	switch/prox input, relay
MTL4617		2	switch/prox input, relay + LFD alarm
MTL4619L		1	24V/48V digital input
MTL4619H		1	110Vac/125Vdc digital input
Digital Output			
MTL4621		1	loop powered solenoid driver
MTL4623		1	solenoid driver with LFD alarm
MTL4623L		1	loop powered solenoid driver with LFD alarm
MTL4623R		1	solenoid driver with reverse LFD alarm
MTL4624		1	switch operated solenoid driver
MTL4624S		1	switch operated solenoid driver, 24V override
MTL4626		2	switch operated relay
MTL4627		1	24V 250mA digital output
MTL4628		1	Relay output
Pulse Output			
MTL4632		1	pulse isolator, digital or analogue output
Analogue Input			
MTL4641		1	2/3 wire transmitter repeater
MTL4641A		1	transmitter repeater, passive input
MTL4641AS		1	transmitter repeater, passive input, current sink
MTL4641S		1	2/3 wire transmitter repeater, current sink
MTL4644		2	2/3 wire transmitter repeater
MTL4644A		2	transmitter repeater, passive input
MTL4644AS		2	transmitter repeater, passive input, current sink
MTL4644S		2	2/3 wire transmitter repeater, current sink
MTL4644D		1	2/3 wire transmitter repeater, dual output
Analogue Output			
MTL4646		1	4-20mA smart isolating driver + LFD
MTL4646Y		1	4-20mA smart isolating driver + oc LFD
MTL4649		2	4-20mA smart isolating driver + LFD
MTL4649Y		2	4-20mA smart isolating driver + oc LFD
Temperature Input			
MTL4675		1	temperature converter, THC or RTD
MTL4676-RTD		2	temperature converter, RTD
MTL4676-THC		2	temperature converter, THC



Powering Business Worldwide

Eaton Electric Limited,
Great Marlings, Butterfield, Luton
Beds, LU2 8DL, UK.
Tel: + 44 (0)1582 723633 Fax: + 44 (0)1582 422283
E-mail: mtlenquiry@eaton.com
www.mtl-inst.com

© 2016 Eaton
All Rights Reserved
Publication No.
EPS4600 Rev 5 010916

EUROPE (EMEA):
+44 (0)1582 723633 mtlenquiry@eaton.com
THE AMERICAS:
+1 800 835 7075 mtl-us-info@eaton.com
ASIA-PACIFIC:
+65 6 645 9888 sales.mtlsing@eaton.com

MTL4604

SWITCH/ PROXIMITY DETECTOR INTERFACE

1-channel with LFD and phase reversal

The MTL4604 enables a load to be controlled, through a relay, by a proximity detector or switch. Line faults are signalled through a separate relay and indicated on the top of the module. MTBF information for the LFD relay is available from Eaton to allow the failure rate for the LFD relay to be calculated when used in the critical path with the output relay for safety critical applications. Switches are provided to select phase reversal and to enable the line fault detection.

SPECIFICATION

See also common specification

Number of channels

One

Inputs

Inputs conforming to BS EN60947-5-6:2001 standards for proximity detectors (NAMUR)

Voltage applied to sensor

7 to 9V dc from $1k\Omega \pm 10\%$

Input/output characteristics

Normal phase

Outputs closed if input $> 2.1mA$ ($< 2k\Omega$ in input circuit)

Outputs open if input $< 1.2mA$ ($> 10k\Omega$ in input circuit)

Hysteresis: $200\mu A$ (650Ω) nominal

Line fault detection (LFD) (when selected)

User-selectable via switches on the side of the unit. Line faults are indicated by an LED. Line fault relay is de-energised and channel output relay de-energised if input line-fault detected

Open-circuit alarm on if $I_{in} < 50\mu A$

Open-circuit alarm off if $I_{in} > 250\mu A$

Short-circuit alarm on if $R_{in} < 100\Omega$

Short-circuit alarm off if $R_{in} > 360\Omega$

Note: Resistors must be fitted when using the LFD facility with a contact input
 500Ω to $1k\Omega$ in series with switch
 $20k\Omega$ to $25k\Omega$ in parallel with switch

Output

Channel: Single pole relay with changeover contacts

LFD: Single pole relay with changeover contacts

Note: reactive loads must be adequately suppressed

Relay characteristics

Response time: 10ms maximum

Contact rating: 10W, 0.5A, 35V dc

MTL4604

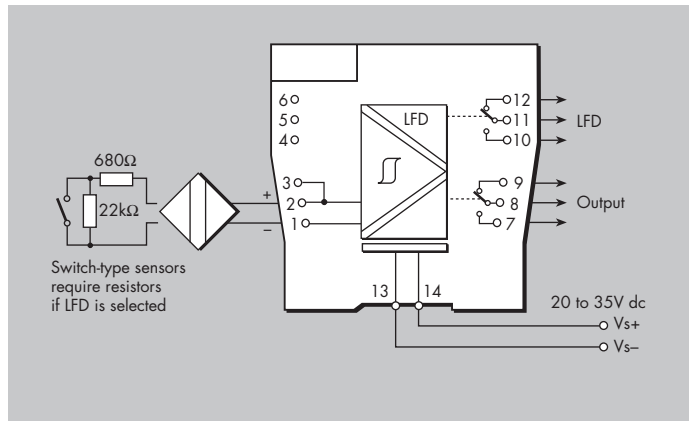

LED indicators

Green: power indication

Yellow: channel status, on when output energised

Red: LFD indication, on when line fault detected

Maximum current consumption

25mA at 24V dc

Power dissipation within unit

0.6W at 24V

The given data is only intended as a product description and should not be regarded as a legal warranty of properties or guarantee. In the interest of further technical developments, we reserve the right to make design changes.



Powering Business Worldwide

Eaton Electric Limited,

Great Marlings, Butterfield, Luton
Beds, LU2 8DL, UK.

Tel: + 44 (0)1582 723633 Fax: + 44 (0)1582 422283

E-mail: mtlenquiry@eaton.com

www.mtl-inst.com

© 2016 Eaton

All Rights Reserved

Publication No.

EPS4604 Rev 3 010916

EUROPE (EMEA):

+44 (0)1582 723633 mtlenquiry@eaton.com

THE AMERICAS:

+1 800 835 7075 mtl-us-info@eaton.com

ASIA-PACIFIC:

+65 6 645 9888 sales.mtlsing@eaton.com

MTL4610

SWITCH/ PROXIMITY DETECTOR INTERFACE

4-channel, digital input

The MTL4610 enables four solid-state outputs to be controlled by up to four switches or proximity detectors. Each pair of output transistors shares a common terminal and can switch +ve or -ve polarity signals. A range of module configurations is available (see Table 1) through the use of selector switches. When proximity detector modes are selected, LFD is enabled and the output switches to OFF if a line fault is detected.

SPECIFICATION

See also common specification

Number of channels

4, configured by switches

Inputs

Inputs conforming to BS EN60947-5-6:2001 standards for proximity detectors (NAMUR)

Voltage applied to sensor

7 to 9V dc from 1kΩ ±10%

Input/output characteristics

Normal phase

Outputs closed if input > 2.1mA (< 2kΩ in input circuit)

Outputs open if input < 1.2mA (> 10kΩ in input circuit)

Hysteresis: 200µA (650Ω) nominal

Line fault detection (LFD) (when selected)

User-selectable via switches on the side of the unit.

Open-circuit alarm on if $I_{in} < 50\mu A$

Open-circuit alarm off if $I_{in} > 250\mu A$

Short-circuit alarm on if $R_{in} < 100\Omega$

Short-circuit alarm off if $R_{in} > 360\Omega$

Note: Resistors must be fitted when using the LFD facility with a contact input
500Ω to 1kΩ in series with switch
20kΩ to 25kΩ in parallel with switch

Outputs

Floating solid-state outputs compatible with logic circuits

Operating frequency: dc to 500Hz

Max. off-state voltage: ± 35V

Max. off-state leakage current: ± 50µA

Max. on-state resistance: 25Ω

Max. on-state current: ± 50mA

LED indicators

Green: power indication

Yellow: four: on when output active

Red: LFD indication + faulty channel's yellow LED flashes

Maximum current consumption

40mA at 24V (with all output channels energised)

Power dissipation within unit

0.96W at 24V, with 10mA loads

MTL4610

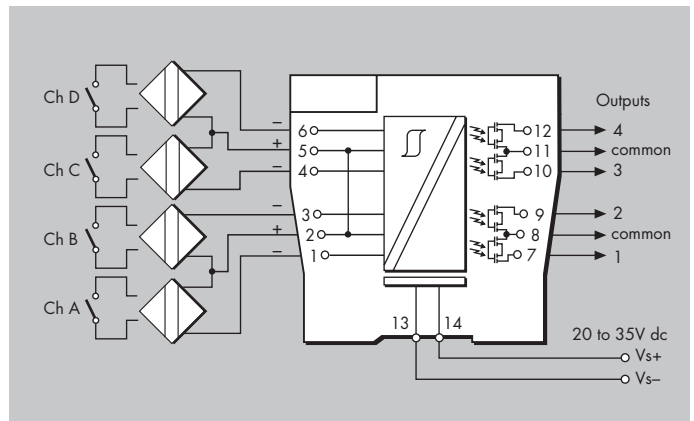

Table 1 - Mode options

MODE	o/p 1	o/p 2	o/p 3	o/p 4	i/p type
0	chA	chB	chC	chD	switch
1	chA rev.	chB	chC	chD	
2	chA	chB rev.	chC	chD	
3	chA	chB	chC rev.	chD	
4	chA	chB	chC	chD rev.	
5	chA rev.	chB	chC rev.	chD	
6	chA	chB rev.	chC	chD rev.	
7	chA rev.	chB rev.	chC rev.	chD rev.	
8	chA	chB	chC	chD	prox. detector + LFD
9	chA rev.	chB	chC	chD	
10	chA	chB rev.	chC	chD	
11	chA	chB	chC rev.	chD	
12	chA	chB	chC	chD rev.	
13	chA rev.	chB	chC rev.	chD	
14	chA	chB rev.	chC	chD rev.	
15	chA rev.	chB rev.	chC rev.	chD rev.	

See Instruction Manual INM4500 for further mode information.



Powering Business Worldwide

Eaton Electric Limited,

Great Marlings, Butterfield, Luton
Beds, LU2 8DL, UK.
Tel: + 44 (0)1582 723633 Fax: + 44 (0)1582 422283
E-mail: mtlenquiry@eaton.com
www.mtl-inst.com

© 2016 Eaton
All Rights Reserved
Publication No.
EPS4610 Rev 2 010916

EUROPE (EMEA):

+44 (0)1582 723633 mtlenquiry@eaton.com

THE AMERICAS:

+1 800 835 7075 mt-us-info@eaton.com

ASIA-PACIFIC:

+65 6 645 9888 sales.mtlsing@eaton.com

The given data is only intended as a product description and should not be regarded as a legal warranty of properties or guarantee.

In the interest of further technical developments, we reserve the right to make design changes.

MTL4611

SWITCH/ PROXIMITY DETECTOR INTERFACE

1-channel, with line fault detection

The MTL4611 enables a load to be controlled by a switch or proximity detector. When selected, open or short circuit conditions in the field wiring are detected by the line-fault-detect (LFD) facility and also indicated on the top of the module. Phase reversal for the channel is selected by a switch on the side of the module and output is provided by changeover relay contacts.

SPECIFICATION

See also common specification

Number of channels

One

Inputs

Inputs conforming to BS EN60947-5-6:2001 standards for proximity detectors (NAMUR)

Voltage applied to sensor

7 to 9V dc from $1k\Omega \pm 10\%$

Input/output characteristics

Normal phase

Outputs closed if input $> 2.1mA$ ($< 2k\Omega$ in input circuit)

Outputs open if input $< 1.2mA$ ($> 10k\Omega$ in input circuit)

Hysteresis: $200\mu A$ (650Ω) nominal

Line fault detection (LFD) (when selected)

User-selectable via switches on the side of the unit. A line fault is indicated by an LED. The channel output relay is de-energised if an input line fault is detected.

Open-circuit alarm on if $I_{in} < 50\mu A$

Open-circuit alarm off if $I_{in} > 250\mu A$

Short-circuit alarm on if $R_{in} < 100\Omega$

Short-circuit alarm off if $R_{in} > 360\Omega$

Note: Resistors must be fitted when using the LFD facility with a contact input
 500Ω to $1k\Omega$ in series with switch
 $20k\Omega$ to $25k\Omega$ in parallel with switch

Output

Single pole relay with changeover contacts

Note: reactive loads must be adequately suppressed

Relay characteristics

Response time: 10ms maximum

Contact rating: 10W, 0.5A, 35V dc

MTL4611

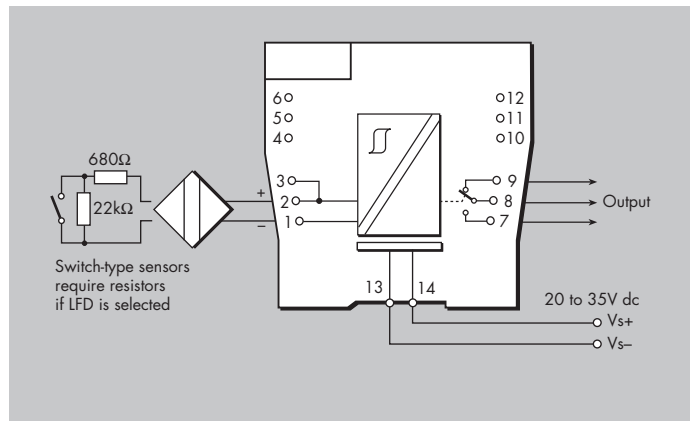

LED indicators

Green: power indication

Yellow: channel status, on when output energised

Red: LFD indication, on when line fault detected

Maximum current consumption

25mA at 24V

Power dissipation within unit

0.6W at 24V

The given data is only intended as a product description and should not be regarded as a legal warranty of properties or guarantee. In the interest of further technical developments, we reserve the right to make design changes.



Powering Business Worldwide

Eaton Electric Limited,

Great Marlings, Butterfield, Luton
Beds, LU2 8DL, UK.

Tel: +44 (0)1582 723633 Fax: +44 (0)1582 422283

E-mail: mtl enquiry@eaton.com

www.mtl-inst.com

© 2016 Eaton

All Rights Reserved

Publication No.

EPS4611 Rev 3 010916

EUROPE (EMEA):

+44 (0)1582 723633 mtl enquiry@eaton.com

THE AMERICAS:

+1 800 835 7075 mtl-us-info@eaton.com

ASIA-PACIFIC:

+65 6 645 9888 sales.mtlsing@eaton.com

MTL4614 SWITCH/ PROXIMITY DETECTOR INTERFACE

1-channel, line fault detection, phase reversal

The MTL4614 enables a load to be controlled, through a relay, by a proximity detector or switch. Line faults are signalled through a separate relay and indicated on the top of the module. Switches are provided to select phase reversal and to enable the line fault detection.

SPECIFICATION

See also common specification

Number of channels

One

Inputs

Inputs conforming to BS EN60947-5-6:2001 standards for proximity detectors (NAMUR)

Voltage applied to sensor

7 to 9V dc from $1k\Omega \pm 10\%$

Input/output characteristics

Normal phase

Outputs closed if input $> 2.1mA$ ($< 2k\Omega$ in input circuit)

Outputs open if input $< 1.2mA$ ($> 10k\Omega$ in input circuit)

Hysteresis: $200\mu A$ (650Ω) nominal

Line fault detection (LFD) (when selected)

User-selectable via switches on the side of the unit. Line faults are indicated by an LED. Line fault relay is energised and channel output relay de-energised if input line-fault detected

Open-circuit alarm on if $I_{in} < 50\mu A$

Open-circuit alarm off if $I_{in} > 250\mu A$

Short-circuit alarm on if $R_{in} < 100\Omega$

Short-circuit alarm off if $R_{in} > 360\Omega$

Note: Resistors must be fitted when using the LFD facility with a contact input
 500Ω to $1k\Omega$ in series with switch
 $20k\Omega$ to $25k\Omega$ in parallel with switch

Output

Channel: Single pole relay with changeover contacts

LFD: Single pole relay with changeover contacts

Note: reactive loads must be adequately suppressed

Relay characteristics

Response time: 10ms maximum

Contact rating: 10W, 0.5A, 35V dc

MTL4614

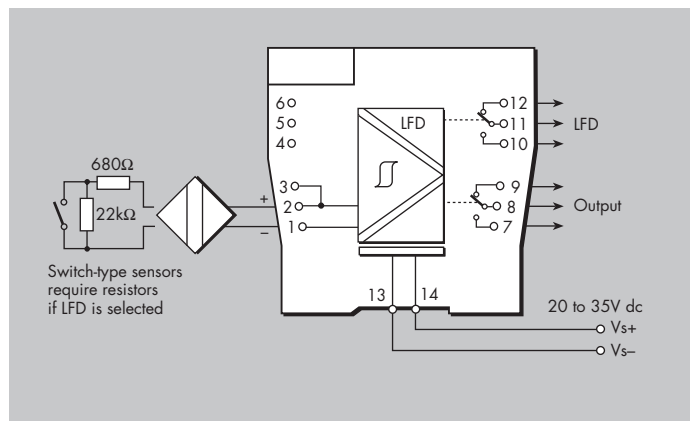

LED indicators

Green: power indication

Yellow: channel status, on when output energised

Red: LFD indication, on when line fault detected

Maximum current consumption

25mA at 24V dc

Power dissipation within unit

0.6W at 24V

The given data is only intended as a product description and should not be regarded as a legal warranty of properties or guarantee. In the interest of further technical developments, we reserve the right to make design changes.



Powering Business Worldwide

Eaton Electric Limited,

Great Marlings, Butterfield, Luton
Beds, LU2 8DL, UK.

Tel: + 44 (0)1582 723633 Fax: + 44 (0)1582 422283

E-mail: mtlenquiry@eaton.com

www.mtl-inst.com

© 2016 Eaton

All Rights Reserved

Publication No.

EPS4614 Rev 3 010916

EUROPE (EMEA):

+44 (0)1582 723633 mtlenquiry@eaton.com

THE AMERICAS:

+1 800 835 7075 mtl-us-info@eaton.com

ASIA-PACIFIC:

+65 6 645 9888 sales.mtlsing@eaton.com

MTL4614D SWITCH/ PROXIMITY DETECTOR INTERFACE

1-channel, dual output, LFD, phase reversal

The MTL4614D enables two safe-area loads to be controlled, through relays, by a proximity detector or switch. When selected, open or short circuit conditions in the field wiring are detected by the line fault detect (LFD) facility and indicated on the top of the module. Switches are provided to select phase reversal and to enable the line fault detection.

SPECIFICATION

See also common specification

Number of channels

One

Inputs

Inputs conforming to BS EN60947-5-6:2001 standards for proximity detectors (NAMUR)

Voltage applied to sensor

7 to 9V dc from $1k\Omega \pm 10\%$

Input/output characteristics

Normal phase

Outputs closed if input $> 2.1mA$ ($< 2k\Omega$ in input circuit)

Outputs open if input $< 1.2mA$ ($> 10k\Omega$ in input circuit)

Hysteresis: $200\mu A$ (650Ω) nominal

Line fault detection (LFD) (when selected)

User-selectable via switches on the side of the unit. Line faults are indicated by an LED. The channel output relays are de-energised if an input line-fault is detected

Open-circuit alarm on if $I_{in} < 50\mu A$

Open-circuit alarm off if $I_{in} > 250\mu A$

Short-circuit alarm on if $R_{in} < 100\Omega$

Short-circuit alarm off if $R_{in} > 360\Omega$

Note: Resistors must be fitted when using the LFD facility with a contact input
 500Ω to $1k\Omega$ in series with switch
 $20k\Omega$ to $25k\Omega$ in parallel with switch

Output

Two, single pole relays with normally-open contacts

Note: reactive loads must be adequately suppressed

Relay characteristics

Contact rating: 10W, 0.5A, 35V dc

LED indicators

Green: power indication

Yellow: channel status, on when output energised

Red: LFD indication, on when line fault detected

Maximum current consumption

29mA at 24V dc

Power dissipation within unit

0.7W at 24V

MTL4614D

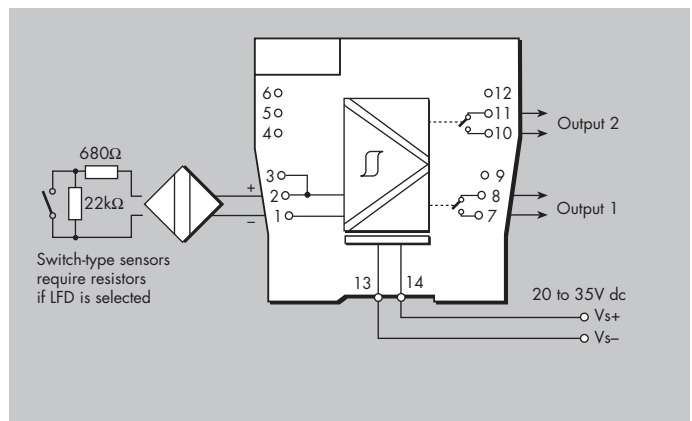

* Signal plug SAF1-3 is required for access to this function

The given data is only intended as a product description and should not be regarded as a legal warranty of properties or guarantee. In the interest of further technical developments, we reserve the right to make design changes.



Powering Business Worldwide

Eaton Electric Limited,
 Great Marlings, Butterfield, Luton
 Beds, LU2 8DL, UK.
 Tel: + 44 (0)1582 723633 Fax: + 44 (0)1582 422283
 E-mail: mtlenquiry@eaton.com
www.mtl-inst.com

© 2016 Eaton
 All Rights Reserved
 Publication No.
 EPS4614D Rev 2 010916

EUROPE (EMEA):
 +44 (0)1582 723633 mtlenquiry@eaton.com
THE AMERICAS:
 +1 800 835 7075 mtl-us-info@eaton.com
ASIA-PACIFIC:
 +65 6 645 9888 sales.mtlsing@eaton.com

MTL4616

SWITCH/ PROXIMITY DETECTOR INTERFACE

2-channel, with line fault detection

The MTL4616 enable two loads to be controlled by a switch or proximity detector. When selected, open or short circuit conditions in the field wiring are detected by the line-fault-detect (LFD) facility and also indicated on the top of the module. Phase reversal for each channel is selected by a switch on the side of the module and output is provided by changeover relay contacts.

SPECIFICATION

See also common specification

Number of channels

Two

Inputs

Inputs conforming to BS EN60947-5-6:2001 standards for proximity detectors (NAMUR)

Voltage applied to sensor

7 to 9V dc from $1k\Omega \pm 10\%$

Input/output characteristics

Normal phase

Outputs closed if input $> 2.1mA$ ($< 2k\Omega$ in input circuit)

Outputs open if input $< 1.2mA$ ($> 10k\Omega$ in input circuit)

Hysteresis: $200\mu A$ (650Ω) nominal

Line fault detection (LFD) (when selected)

User-selectable via switches on the side of the unit. Line faults are indicated by an LED for each channel. The channel output relay is de-energised if an input line fault is detected.

Open-circuit alarm on if $I_{in} < 50\mu A$

Open-circuit alarm off if $I_{in} > 250\mu A$

Short-circuit alarm on if $R_{in} < 100\Omega$

Short-circuit alarm off if $R_{in} > 360\Omega$

Note: Resistors must be fitted when using the LFD facility with a contact input
 500Ω to $1k\Omega$ in series with switch
 $20k\Omega$ to $25k\Omega$ in parallel with switch

Output

Two single-pole relays with changeover contacts

Note: reactive loads must be adequately suppressed

Relay characteristics

Response time: 10ms maximum

Contact rating: 10W, 0.5A, 35V dc

MTL4616

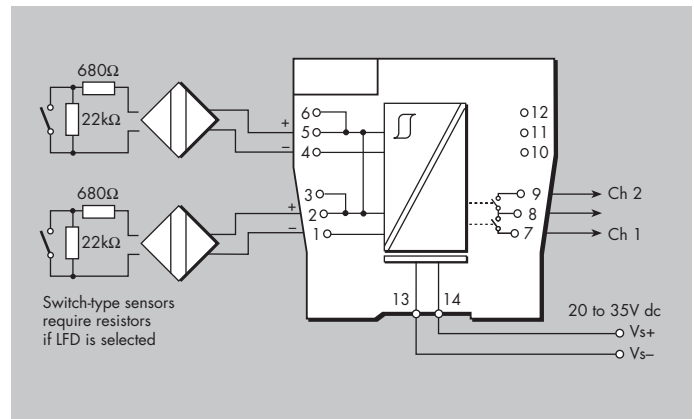

LED indicators

Green: power indication

Yellow: two: channel status, on when output energised

Red: two: LFD indication, on when line fault detected

Maximum current consumption

35mA at 24V

Power dissipation within unit

0.84W at 24V

The given data is only intended as a product description and should not be regarded as a legal warranty of properties or guarantee. In the interest of further technical developments, we reserve the right to make design changes.



Powering Business Worldwide

Eaton Electric Limited,

Great Marlings, Butterfield, Luton
Beds, LU2 8DL, UK.

Tel: + 44 (0)1582 723633 Fax: + 44 (0)1582 422283

E-mail: mtlenquiry@eaton.com

www.mtl-inst.com

© 2016 Eaton

All Rights Reserved

Publication No.

EPS4616 Rev 3 010916

EUROPE (EMEA):

+44 (0)1582 723633 mtlenquiry@eaton.com

THE AMERICAS:

+1 800 835 7075 mtl-us-info@eaton.com

ASIA-PACIFIC:

+65 6 645 9888 sales.mtlsing@eaton.com

MTL4617 SWITCH/ PROXIMITY DETECTOR INTERFACE

2-channel, line fault detection, phase reversal

The MTL4617 enables two loads to be controlled, through a relay, by proximity detectors or switches. Line faults are signalled through a separate relay and indicated on the top of the module. Switches are provided to select phase reversal and to enable the line fault detection.

SPECIFICATION

See also common specification

Number of channels

Two

Inputs

Inputs conforming to BS EN60947-5-6:2001 standards for proximity detectors (NAMUR)

Voltage applied to sensor

7 to 9V dc from 1k Ω \pm 10%

Input/output characteristics

Normal phase

Outputs closed if input > 2.1mA (< 2k Ω in input circuit)

Outputs open if input < 1.2mA (> 10k Ω in input circuit)

Hysteresis: 200 μ A (650 Ω) nominal

Line fault detection (LFD) (when selected)

User selectable by switches on the side of the module.

Line faults are indicated by the LED for each channel.

Line fault relay is energised and channel output relay de-energised if input line-fault detected

Open-circuit alarm on if $I_{in} < 50\mu$ A

Open-circuit alarm off if $I_{in} > 250\mu$ A

Short-circuit alarm on if $R_{in} < 100\Omega$

Short-circuit alarm off if $R_{in} > 360\Omega$

Note: Resistors must be fitted when using the LFD facility with a contact input
500 Ω to 1k Ω in series with switch
20k Ω to 25k Ω in parallel with switch

Output

Channel: Two single-pole relays with normally open contacts

LFD: Single pole relay with changeover contacts

Note: reactive loads must be adequately suppressed

Relay characteristics

Response time: 10ms maximum

Contact rating: 10W, 0.5A, 35V dc

MTL4617

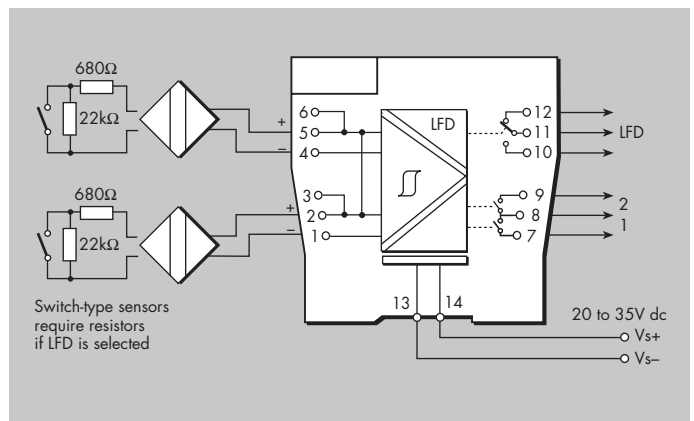

LED indicators

Green: power indication

Yellow: two: channel status, on when output energised

Red: two: LFD indication, on when line fault detected

Maximum current consumption

35mA at 24V

Power dissipation within unit

0.84W at 24V

The given data is only intended as a product description and should not be regarded as a legal warranty of properties or guarantee. In the interest of further technical developments, we reserve the right to make design changes.



Powering Business Worldwide

Eaton Electric Limited,

Great Marlings, Butterfield, Luton
Beds, LU2 8DL, UK.

Tel: + 44 (0)1582 723633 Fax: + 44 (0)1582 422283

E-mail: mtl-enquiry@eaton.com

www.mtl-inst.com

© 2016 Eaton

All Rights Reserved

Publication No.

EPS4617 Rev 3 010916

EUROPE (EMEA):

+44 (0)1582 723633 mtl-enquiry@eaton.com

THE AMERICAS:

+1 800 835 7075 mtl-us-info@eaton.com

ASIA-PACIFIC:

+65 6 645 9888 sales.mtlsing@eaton.com

MTL4619H

DIGITAL INPUT INTERFACE

1 channel for 110Vac /125Vdc digital signals

The MTL4619H is a single channel, high voltage, digital input module with a relay interface to the system. The relay is powered by the field signal.

SPECIFICATION

See also common specification

Number of channels

One, with fully floating output

Location of sensor

Safe area

Input Voltage

80Vac/125Vac /115dc to 135Vdc input

Input Current

9mA RMS @110Vac / 3.5mA @ 125Vdc

Output

Relay, dry contact 10W, 0.5A, 35V dc

Response time

8mS typical, 15mS maximum on / 0.5s off

Power dissipation

0.7w/0.7w @ 125Vdc / 110Vac

Isolation

250V RMS between any input and output

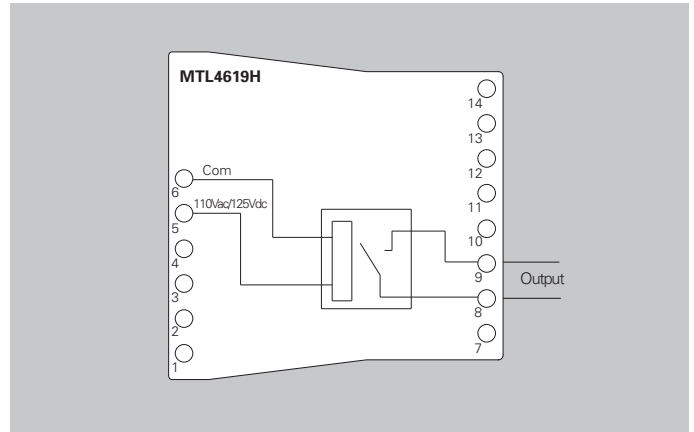

Terminals	Function
5	110 /125V ac/dc input
6	Common
8	Relay contact output
9	Relay contact output



Powering Business Worldwide

Eaton Electric Limited,

Great Marlings, Butterfield, Luton
Beds, LU2 8DL, UK.
Tel: + 44 (0)1582 723633 Fax: + 44 (0)1582 422283
E-mail: mtlenquiry@eaton.com
www.mtl-inst.com

© 2016 Eaton
All Rights Reserved
Publication No.
EPS MTL4619H Rev 1 010916

EUROPE (EMEA):

+44 (0)1582 723633 mtlenquiry@eaton.com

THE AMERICAS:

+1 800 835 7075 mtl-us-info@eaton.com

ASIA-PACIFIC:

+65 6 645 9888 sales.mtlsing@eaton.com

The given data is only intended as a product description and should not be regarded as a legal warranty of properties or guarantee.
In the interest of further technical developments, we reserve the right to make design changes.

MTL4619L

DIGITAL INPUT INTERFACE

1 channel for 24V-48V digital input signals

The MTL4619L is a single channel digital input module with a relay interface to the system. The relay is powered by the field signal.

SPECIFICATION

See also common specification

Number of channels

One, with fully floating output

Location of sensor

Safe area

Input

24V dc (22-32V)

48V dc (42-60V)

Output

Relay, dry contact 10W, 0.5A, 35V dc

Response time

8mS typical, 15mS maximum

Current consumption

14mA @ 24V

Power dissipation

0.4W @24V, 0.7W @ 48V

Isolation

250V RMS between any input and output

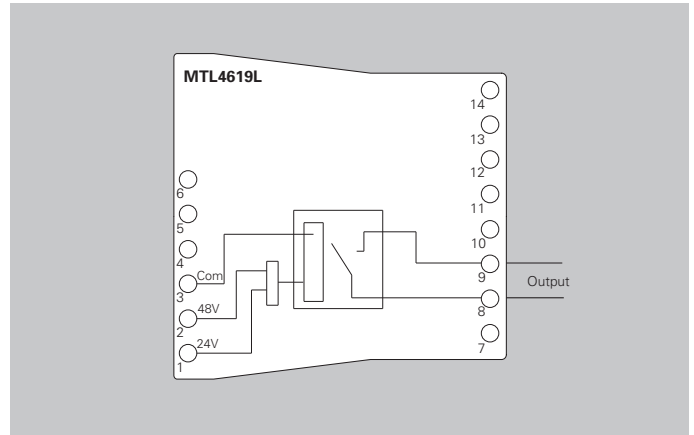

Terminals	Function
1	24V dc input
2	48V dc input
3	Common
8	Relay contact output
9	Relay contact output



Powering Business Worldwide

Eaton Electric Limited,
Great Marlings, Butterfield, Luton
Beds, LU2 8DL, UK.
Tel: + 44 (0)1582 723633 Fax: + 44 (0)1582 422283
E-mail: mtlenquiry@eaton.com
www.mtl-inst.com

© 2016 Eaton
All Rights Reserved
Publication No.
EPS MTL4619L Rev 1 010916

EUROPE (EMEA):
+44 (0)1582 723633 mtlenquiry@eaton.com
THE AMERICAS:
+1 800 835 7075 mtl-us-info@eaton.com
ASIA-PACIFIC:
+65 6 645 9888 sales.mtlsing@eaton.com

The given data is only intended as a product description and should not be regarded as a legal warranty of properties or guarantee.
In the interest of further technical developments, we reserve the right to make design changes.

MTL4621

SOLENOID/ALARM DRIVER

loop-powered

The MTL4621 is a loop-powered module that can drive a low-power load as well as apparatus such as an LED. The unit's input/output isolation allows the control switch to be connected into either side of the 24V dc supply circuit.

SPECIFICATION

See also common specification

Number of channels

One

Minimum output voltage

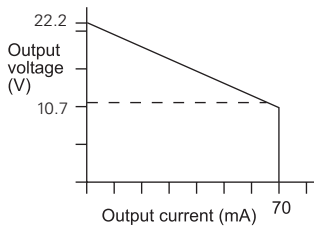

Equivalent output circuit

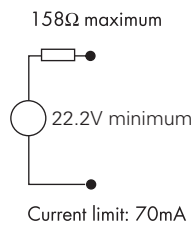

Input voltage

20 to 35V dc

Output

Minimum output voltage: 10.7V at 70mA
 Maximum output voltage: 24V from 158Ω
 Current limit: 70mA

Output ripple

< 0.5% of maximum output, peak to peak

Response time

Output within 10% of final value within 100ms

MTL4621

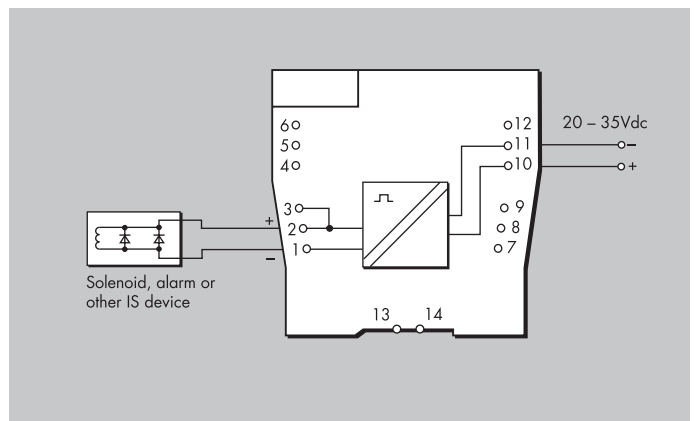

LED indicator

Yellow: output status, on when output active

Maximum current consumption

125mA (typ.) at 24V

Power dissipation within unit

1.4W at 24V

The given data is only intended as a product description and should not be regarded as a legal warranty of properties or guarantee. In the interest of further technical developments, we reserve the right to make design changes.



Powering Business Worldwide

Eaton Electric Limited,
 Great Marlings, Butterfield, Luton
 Beds, LU2 8DL, UK.
 Tel: + 44 (0)1582 723633 Fax: + 44 (0)1582 422283
 E-mail: mtlenquiry@eaton.com
www.mtl-inst.com

© 2016 Eaton
 All Rights Reserved
 Publication No.
 EPS4621 Rev 4 010916

EUROPE (EMEA):
 +44 (0)1582 723633 mtlenquiry@eaton.com
THE AMERICAS:
 +1 800 835 7075 mtl-us-info@eaton.com
ASIA-PACIFIC:
 +65 6 645 9888 sales.mtlsing@eaton.com

MTL4623L

SOLENOID/ ALARM DRIVER

loop-powered with line fault detection

With the MTL4623L interface, an on/off device can be controlled by a voltage signal. It is suitable for driving loads such as solenoids. Line fault detection (LFD), which operates when the output is energised, is signalled by a solid-state switch which energises if a field line is open or short-circuited. Earth fault detection can be provided by connecting an MTL4220 earth leakage detector to terminal 3.

SPECIFICATION

See also common specification

Number of channels

One

Minimum output voltage

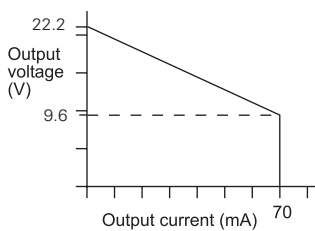

Equivalent output circuit

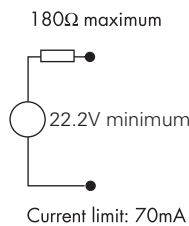

Input voltage

20 to 35V dc

Output

Minimum output voltage: 9.6V at 70mA
Maximum output voltage: 24V from 180Ω
Current limit: 70mA

Output ripple

< 0.5% of maximum output, peak to peak

Response time

Output within 10% of final value within 100ms

Line fault detection (LFD)

Open or short circuit in field cabling energises solid state line fault signal
LFD transistor is switched on, provided that the field circuit impedance is > 55Ω and < 4kΩ.

Line fault signal characteristics

Maximum off-state voltage: 35V
Maximum off-state leakage current: 10μA
Maximum on-state voltage drop: 2V
Maximum on-state current: 50mA
Note: LFD signal is Zener-diode protected against inductive loads

MTL4623L

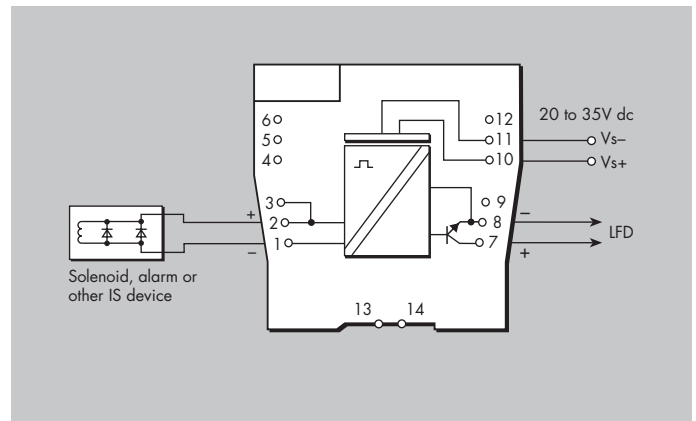

LED indicators

Yellow: output status, on when output active
Red: LFD indication, on when line fault detected

Maximum current consumption

125mA at 24V dc

Power dissipation within unit

1.4W with typical solenoid valve, output on

The given data is only intended as a product description and should not be regarded as a legal warranty of properties or guarantee. In the interest of further technical developments, we reserve the right to make design changes.



Powering Business Worldwide

Eaton Electric Limited,
Great Marlings, Butterfield, Luton
Beds, LU2 8DL, UK.
Tel: + 44 (0)1582 723633 Fax: + 44 (0)1582 422283
E-mail: mtlenquiry@eaton.com
www.mtl-inst.com

© 2016 Eaton
All Rights Reserved
Publication No.
EPS4623L Rev 3 010916

EUROPE (EMEA):
+44 (0)1582 723633 mtlenquiry@eaton.com
THE AMERICAS:
+1 800 835 7075 mtl-us-info@eaton.com
ASIA-PACIFIC:
+65 6 645 9888 sales.mtlsing@eaton.com

MTL4623 / MTL4623R

SOLENOID/ALARM DRIVER

with line fault detection, IIC

With the MTL4623 interface, an on/off device can be controlled by a volt-free contact or logic signal. It is suitable for driving loads such as solenoids. Line fault detection (LFD), which operates irrespective of the output state, is signalled by a solid-state switch which de-energises MTL4623, or energises MTL4623R, if a field line is open or short-circuited. Earth fault detection can be provided by connecting an MTL4220 earth leakage detector to terminal 3.

SPECIFICATION

See also common specification

Number of channels

One

Minimum output voltage

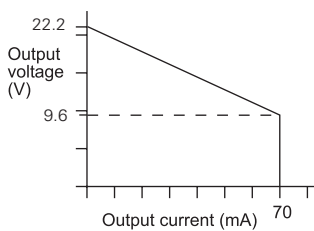

Equivalent output circuit

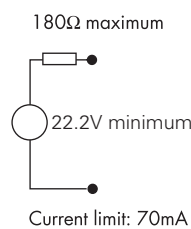

Output

Minimum output voltage: 9.6V at 70mA
 Maximum output voltage: 24V from 180Ω
 Current limit: 70mA

Output ripple

< 0.5% of maximum output, peak to peak

Control input

Suitable for switch contacts, an open collector transistor or logic drive. (Internal contact wetting voltage 12V @ 0.2mA contact closed. Not suitable for voltage control via series diode.)
 Output turns on if input switch closed, transistor on or < 1.4V applied across control input
 Output turns off if input switch open, transistor off or > 4.5V applied across control input

Response time

Output within 10% of final value within 100ms

Line fault detection (LFD)

Open or short circuit in field cabling de-energises* solid state line-fault signal.

LFD transistor is switched on*, provided that the field circuit impedance is > 55Ω and < 4kΩ.

* These conditions are reversed for the MTL4623R. This is to permit parallel connection of alarms between modules to provide a group alarm output.

Line fault signal characteristics

Maximum off-state voltage: 35V
 Maximum off-state leakage current: 10μA
 Maximum on-state voltage drop: 2V
 Maximum on-state current: 50mA

MTL4623 / MTL4623R

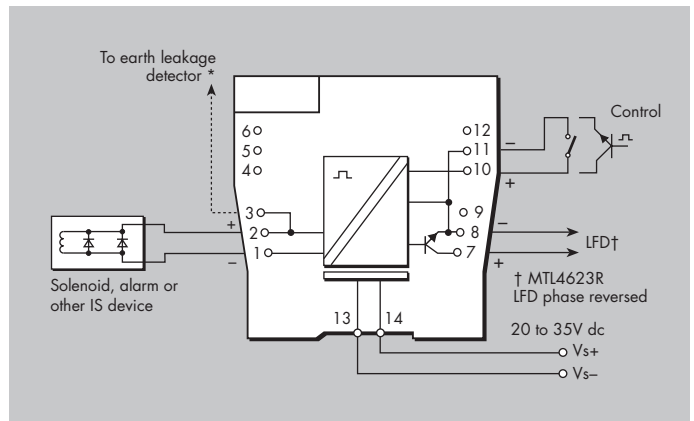

LED indicators

Green: power indication
 Yellow: output status, on when output active
 Red: LFD indication, on when line fault detected

Maximum current consumption

125mA at 24V dc

Power dissipation within unit

1.4W with typical solenoid valve, output on
 2.0W worst case

The given data is only intended as a product description and should not be regarded as a legal warranty of properties or guarantee. In the interest of further technical developments, we reserve the right to make design changes.



Powering Business Worldwide

Eaton Electric Limited,
 Great Marlings, Butterfield, Luton
 Beds, LU2 8DL, UK.
 Tel: + 44 (0)1582 723633 Fax: + 44 (0)1582 422283
 E-mail: mtlenquiry@eaton.com
 www.mtl-inst.com

© 2016 Eaton
 All Rights Reserved
 Publication No.
 EPS4623/R Rev 5 010916

EUROPE (EMEA):
 +44 (0)1582 723633 mtlenquiry@eaton.com
THE AMERICAS:
 +1 800 835 7075 mtl-us-info@eaton.com
ASIA-PACIFIC:
 +65 6 645 9888 sales.mtlsing@eaton.com

MTL4624

SOLENOID/ALARM DRIVER

switch operated with override

The MTL4624 enables an on/off device to be controlled by a volt-free contact or logic signal. It can drive loads such as solenoids, alarms, LEDs and other low power devices.

The MTL4624 allows a second switch or logic signal to be connected enabling the output to be disabled to permit, for example, a safety system to override a control signal.

SPECIFICATION

See also common specification

Number of channels

One

Minimum output voltage

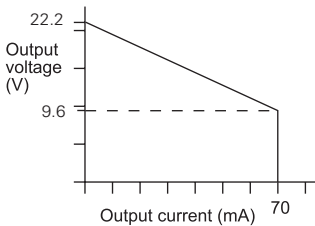

Equivalent output circuit

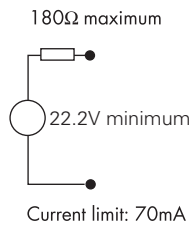

Output

Minimum output voltage: 9.6V at 70mA
Maximum output voltage: 24V from 180Ω
Current limit: 70mA

Output ripple

< 0.5% of maximum output, peak-to-peak

Control input

Suitable for switch contacts, an open collector transistor or logic drive

0 = input switch closed, transistor on or <1.4V applied

1 = input switch open, transistor off or >4.5V applied

Override input

An open collector transistor or a switch connected across the terminals can be used to turn the output off whatever the state of the control input

0 = transistor on or switch closed

1 = transistor off or switch open

Control and override inputs

Control input	Override input	Output state
0	0	off
0	1	on
1	0	off
1	1	off

Response time

Output within 10% of final value within 100ms

MTL4624

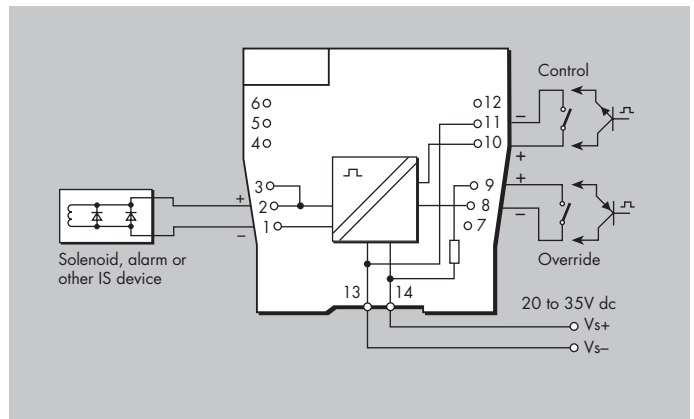

LED indicators

Green: power indication

Yellow: output status, on when output active

Maximum current consumption

125mA at 24V dc

Power dissipation within unit

1.4W with typical solenoid valve, output on

1.9W worst case

The given data is only intended as a product description and should not be regarded as a legal warranty of properties or guarantee. In the interest of further technical developments, we reserve the right to make design changes.



Powering Business Worldwide

Eaton Electric Limited,
Great Marlings, Butterfield, Luton
Beds, LU2 8DL, UK.
Tel: + 44 (0)1582 723633 Fax: + 44 (0)1582 422283
E-mail: mtlenquiry@eaton.com
www.mtl-inst.com

© 2016 Eaton
All Rights Reserved
Publication No.
EPS4624 Rev 3 010916

EUROPE (EMEA):
+44 (0)1582 723633 mtlenquiry@eaton.com
THE AMERICAS:
+1 800 835 7075 mtl-us-info@eaton.com
ASIA-PACIFIC:
+65 6 645 9888 sales.mtlsing@eaton.com

MTL4624S

SOLENOID/ALARM DRIVER

switch operated with 24V override

The MTL4624S enables an on/off device to be controlled by a volt-free contact or a floating logic signal. It can drive loads such as solenoids, alarms, LEDs and other low power devices. By connecting a second voltage, the output can be disabled to permit, for example, a safety system to override a control signal.

SPECIFICATION

See also common specification

Number of channels

One

Minimum output voltage

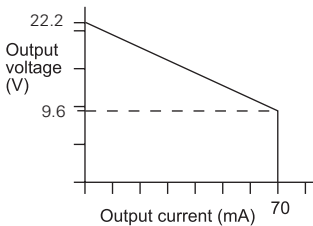

Equivalent output circuit

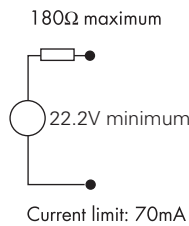

Output

Minimum output voltage: 9.6V at 70mA
Maximum output voltage: 24V from 180Ω
Current limit: 70mA

Output ripple

< 0.5% of maximum output, peak-to-peak

Control input (must be fully-floating)

Suitable for switch contacts or an opto-isolator
0 = input switch closed, transistor on or < 1.4V applied
1 = input switch open, transistor off or > 4.5V applied

Override input

A 24V logic signal applied across the terminals allows the solenoid/ alarm to be operated by the control input. If it is disconnected, the solenoid/alarm is off.
0 = < 2.0V applied across terminals 8 & 9
1 = > 9.0V applied across terminals 8 & 9
(nominal switching point 4.5V)

Control and override inputs

Control input	Override input	Output state
0	0	off
0	1	on
1	0	off
1	1	off

Response time

Output within 10% of final value within 100ms

MTL4624S

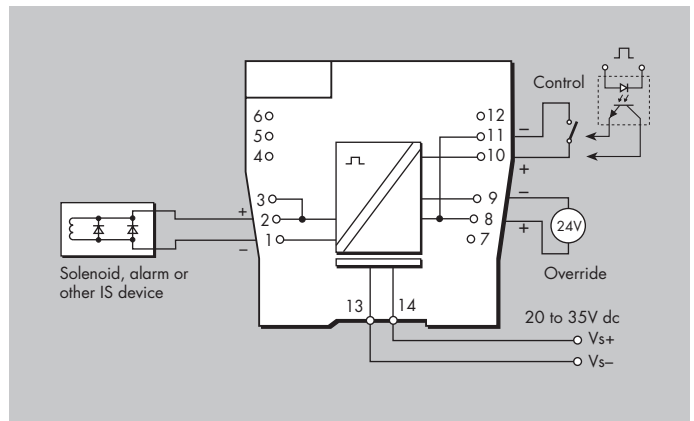

LED indicators

Green: power indication
Yellow: output status, on when output active

Maximum current consumption

125mA at 24V dc

Power dissipation within unit

1.4W with typical solenoid valve, output on
1.9W worst case

The given data is only intended as a product description and should not be regarded as a legal warranty of properties or guarantee. In the interest of further technical developments, we reserve the right to make design changes.



Powering Business Worldwide

Eaton Electric Limited,
Great Marlings, Butterfield, Luton
Beds, LU2 8DL, UK.
Tel: + 44 (0)1582 723633 Fax: + 44 (0)1582 422283
E-mail: mtlenquiry@eaton.com
www.mtl-inst.com

© 2016 Eaton
All Rights Reserved
Publication No.
EPS4624S Rev 3 010916

EUROPE (EMEA):
+44 (0)1582 723633 mtlenquiry@eaton.com
THE AMERICAS:
+1 800 835 7075 mtl-us-info@eaton.com
ASIA-PACIFIC:
+65 6 645 9888 sales.mtlsing@eaton.com

MTL4626

SWITCH-OPERATED RELAY

2-channel switched output

The MTL4626 enables two separate circuits to be contact controlled by one or two, on/off, control inputs. Applications include the calibration of strain-gauge bridges; changing the polarity (and thereby the tone) of a sounder; the testing of fire alarms; and the transfer of signals into an annunciator with input terminals not segregated from each other.

SPECIFICATION

See also common specification

Number of channels

Two, fully floating

Input/output characteristics

Contact/Logic mode

(Inputs suitable for switch contacts, an open-collector transistor or logic drive)

Relay energised if < 450Ω or < 1V applied

Relay de-energised if > 5kΩ or > 2V applied (35V max.)

Loop powered mode

Relay energised if >20V

Relay de-energised if <17V

Power supply failure protection

Relays de-energised if supply fails

Response time

25ms nominal

Contacts

1-pole changeover per channel

Contact rating

250V dc, 2A

(reactive loads must be suppressed)

Contact life expectancy

10 x 10⁶ operations at maximum load

Relay drive (see switch setting table)

Choice of "loop-powered" or "contact/logic" control, for both channels, by switch selection. A further switch option ("1in2out") enables either input, in contact/logic mode, to activate both outputs.

MTL4626

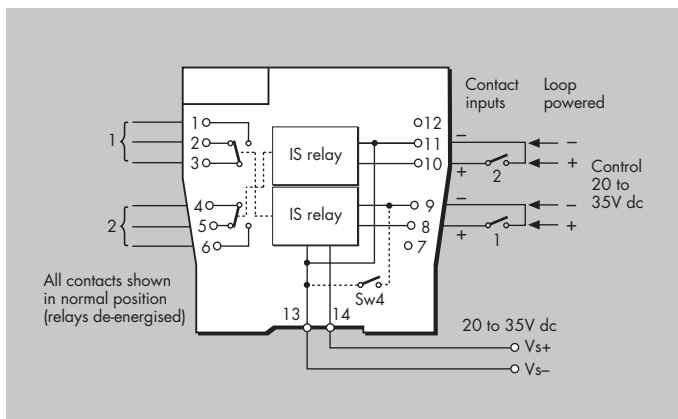

LED indicators

Green: power indication

Yellow: two: output status, on when relay energised

Power requirement, Vs

41mA at 20V dc

44mA at 24V dc

60mA at 35V dc

Power dissipation within unit

1.1W maximum at 24V

User switch settings for operating mode

Mode	Function	SW1	SW2	SW3	SW4
Contact/Logic	2 ch	Off	On	On	On
	Input	On	On	On	On
Loop Powered	2 ch	Off	Off	Off	Off

The given data is only intended as a product description and should not be regarded as a legal warranty of properties or guarantee. In the interest of further technical developments, we reserve the right to make design changes.



Powering Business Worldwide

Eaton Electric Limited,

Great Marlings, Butterfield, Luton
Beds, LU2 8DL, UK.
Tel: + 44 (0)1582 723633 Fax: + 44 (0)1582 422283
E-mail: mtlenquiry@eaton.com
www.mtl-inst.com

© 2016 Eaton
All Rights Reserved
Publication No.
EPS4626 Rev 4 010916

EUROPE (EMEA):

+44 (0)1582 723633 mtlenquiry@eaton.com

THE AMERICAS:

+1 800 835 7075 mtl-us-info@eaton.com

ASIA-PACIFIC:

+65 6 645 9888 sales.mtlsing@eaton.com

MTL4627

24V DIGITAL OUTPUT INTERFACE

1 channel for 24Vdc digital signals

The MTL4627 is a single channel module with a relay controlled by the system to switch power to 24V devices such as solenoids and alarms. A self-resetting fuse provides protection for the power feed.

NOTE: These modules must only be used on suitable rated backplanes.

SPECIFICATION

See also common specification

Number of channels

One, 24V from main supply

Location of field device

Safe area

Output ranges

20-32V dc, 250mA maximum

Output

24V dc, internally protected by 400mA resettable fuse

Current consumption

15mA @ 24V plus external load, max 250mA

Power dissipation

0.4W @ 24V

Isolation

None

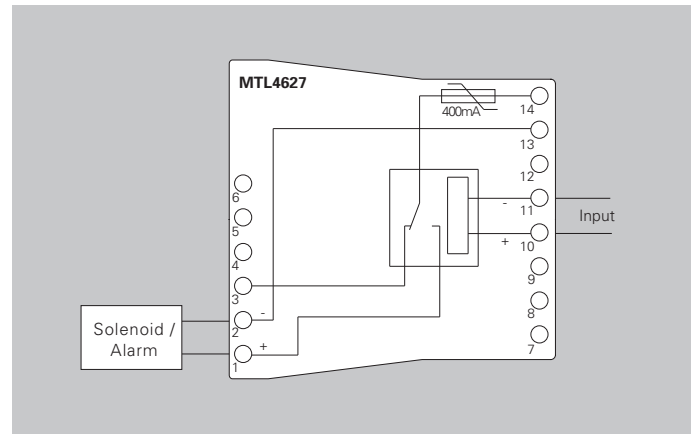

Terminals	Function
1	24V output, normally off
2	24V Common
3	24V output, normally on
10	Control input +ve
11	Control input -ve
13	Power supply -ve
14	Power supply +ve

MTL4628

RELAY INTERFACE

1 channel changeover contacts

The MTL4628 is a single channel module with a relay controlled by the system to switch signals. Power for the field signals is connected externally.

SPECIFICATION

See also common specification

Number of channels

One with normally open and closed contacts

Location of field device

Safe area

Contact ranges

250Vac 2A, 40V dc 2A

Current consumption

10mA @ 24V

Power dissipation

0.25W @24V

Isolation

250V RMS

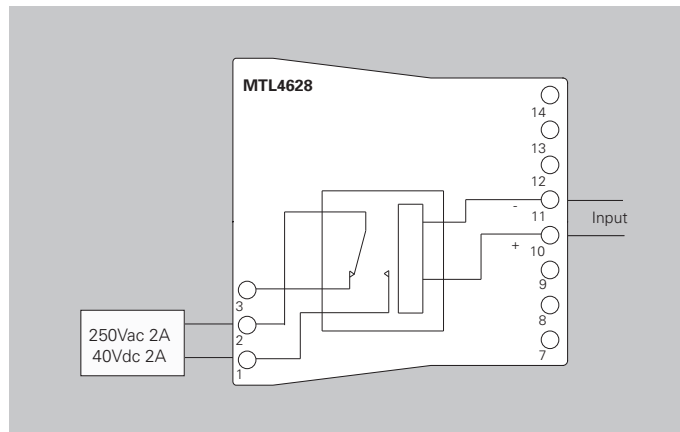

Terminals	Function
1	Relay contact normally open
2	Relay common
3	Relay contact normally closed
10	Relay Control +ve
11	Relay Control -ve



Powering Business Worldwide

Eaton Electric Limited,
Great Marlings, Butterfield, Luton
Beds, LU2 8DL, UK.
Tel: + 44 (0)1582 723633 Fax: + 44 (0)1582 422283
E-mail: mtlenquiry@eaton.com
www.mtl-inst.com

© 2016 Eaton
All Rights Reserved
Publication No.
EPS MTL4628 Rev 1 010916

EUROPE (EMEA):
+44 (0)1582 723633 mtlenquiry@eaton.com
THE AMERICAS:
+1 800 835 7075 mtl-us-info@eaton.com
ASIA-PACIFIC:
+65 6 645 9888 sales.mtlsing@eaton.com

The given data is only intended as a product description and should not be regarded as a legal warranty of properties or guarantee.
In the interest of further technical developments, we reserve the right to make design changes.

MTL4632

PULSE ISOLATOR

pulse & 4/20mA current outputs

The MTL4632 isolates pulses from a switch, proximity detector, current pulse transmitter or voltage pulse transmitter. It is ideal for applications involving high pulse rates and fast response times, by repeating the pulses into an isolated circuit. An analogue output proportional to frequency is also provided, together with a relay output, which may be configured to act as an alarm. Configuration is carried out with a personal computer.

SPECIFICATION

See also common specification

Number of channels

One, fully floating

Sensor type

Switch or proximity detector (NAMUR/BS EN 60947-5-6:2001)
2- or 3-wire voltage or pulse transmitter

Input

Switch input:

Output ON if switch is closed

Proximity detector input:

Excitation: 7.0 to 9.0V dc from 1k Ω nominal

Output ON if input > 2.1mA* (< 2k Ω)

Output OFF if input < 1.2mA* (> 10k Ω)

Switching hysteresis: 0.2mA (650 Ω) nominal

*NAMUR and BS EN 60947-5-6:2001 standards

Current pulse input:

Transmitter supply: 16.5V dc at 20mA

Short circuit current: 24mA

Output: $I_{in} > 9.0mA = ON$, $I_{in} < 7.0mA = OFF$

Switching hysteresis: 0.5mA

Voltage pulse input

Input impedance: > 10k Ω

Switching point voltage (V_{sp}): 3, 6, or 12V nominal

(User selectable by switches on the side of the module)

Output: $V_{in} > V_{sp} = ON$, $V_{in} < V_{sp} = OFF$

Switching hysteresis: 100mV + (0.1 x V_{sp}) typical

Pulse output

Maximum off-state voltage: 35V

Maximum off-state leakage current: 10 μ A

Maximum on-state resistance: 25 Ω

Maximum on-state current: 50mA

Output OFF if supply fails

Note: LFD signal is Zener-diode protected against inductive loads

Current output

Signal range: 4 to 20mA

Under/over range: 0 to 22mA

Load resistance: 0 to 450 Ω @20mA

Output resistance: >1M Ω

Ripple: < 50 μ A peak-to-peak

Accuracy: better than 20 μ A at 20 $^{\circ}$ C

Temperature drift: < 1 μ A/ $^{\circ}$ C

Response delay: TBA ms

Alarm output

Relay ON in alarm, 0.5A @ 35Vdc max.

Pulse width

High: 10 μ s min

Low: 10 μ s min

Frequency range

0 – 50kHz - pulse output mode

0 – 10kHz - for analogue output

MTL4632

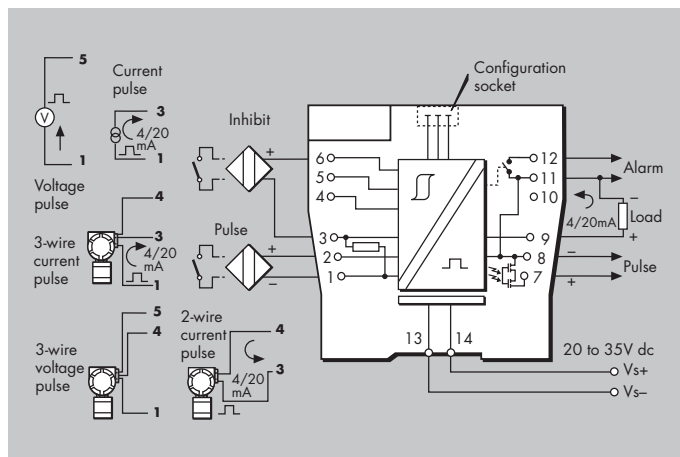

LED indicators

Green: power indication

Yellow: on when output circuit is on

Red: flashing when line fault or error

Power requirement

65mA at 24V dc

70mA at 20V dc

55mA at 35V dc

Power dissipation within unit

1.35W maximum at 24V

1.75W maximum at 35V

Configurator

A personal computer running MTL PCS45 software with a PCL45USB serial interface.

The given data is only intended as a product description and should not be regarded as a legal warranty of properties or guarantee. In the interest of further technical developments, we reserve the right to make design changes.



Powering Business Worldwide

Eaton Electric Limited,

Great Marlings, Butterfield, Luton
Beds, LU2 8DL, UK.
Tel: + 44 (0)1582 723633 Fax: + 44 (0)1582 422283
E-mail: mtlenquiry@eaton.com
www.mtl-inst.com

© 2016 Eaton
All Rights Reserved
Publication No.
EPS4632 Rev 2 010916

EUROPE (EMEA):

+44 (0)1582 723633 mtlenquiry@eaton.com

THE AMERICAS:

+1 800 835 7075 mt-us-info@eaton.com

ASIA-PACIFIC:

+65 6 645 9888 sales.mtlsing@eaton.com

MTL4641A / MTL4641AS CURRENT REPEATER

4/20mA passive i/p for HART® transmitters

The MTL4641A provides an input for separately powered 4/20mA transmitters and also allows bi-directional transmission of HART communication signals superimposed on the 4/20mA loop current. Alternatively, the MTL4641AS acts as a current sink rather than driving a current into the load.

SPECIFICATION

See also common specification

Number of channels

One

Input

Signal range: 4 to 20mA
Under/over-range: 1.0 to 21.5mA

Input impedance for HART signals

at terminals 1, 2: > 230Ω

Maximum input volt drop

at terminals 1, 2: < 6.6V
i.e. a transmitter load of 330Ω at 20mA

Output

Signal range: 4 to 20mA
Under/over-range: 1.0 to 21.5mA
Load resistance (MTL4641A)
Conventional transmitters: 0 to 360Ω
Smart transmitters: 250Ω ±10%
Load (MTL4641AS)
Current sink: 600Ω max.
Maximum voltage source: 24V DC
Circuit output resistance: > 1MΩ

Circuit ripple

< 50μA peak-to-peak up to 80kHz

Transfer accuracy at 20°C

Better than 20μA

Temperature drift

< 1μA/°C

Response time

Settles within 200μA of final value after 20ms

Communications supported

HART

MTL4641A / MTL4641AS

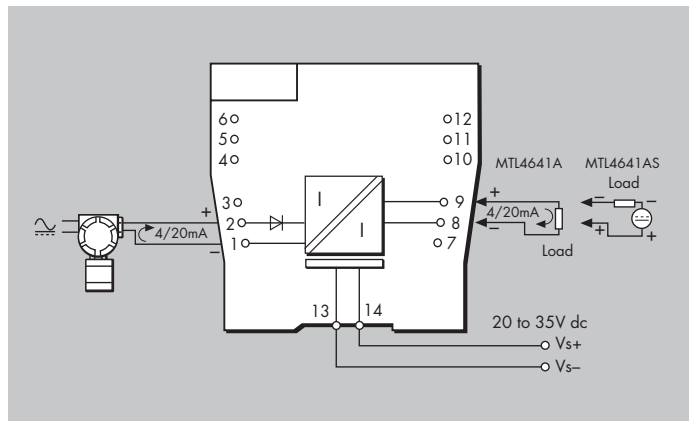

LED indicator

Green: power indication

Power requirement (with 20mA signal)

50mA at 20V
45mA at 24V
35mA at 35V

Power dissipation within unit (with 20mA signals)

MTL4641A 0.8W @ 24V dc
MTL4641AS 1.1W @ 24V dc



Powering Business Worldwide

Eaton Electric Limited,

Great Marlings, Butterfield, Luton
Beds, LU2 8DL, UK.
Tel: + 44 (0)1582 723633 Fax: + 44 (0)1582 422283
E-mail: mtlenquiry@eaton.com
www.mtl-inst.com

© 2016 Eaton
All Rights Reserved
Publication No.
EPS4641A/AS Rev 3 010916

EUROPE (EMEA):

+44 (0)1582 723633 mtlenquiry@eaton.com

THE AMERICAS:

+1 800 835 7075 mtl-us-info@eaton.com

ASIA-PACIFIC:

+65 6 645 9888 sales.mtlsing@eaton.com

The given data is only intended as a product description and should not be regarded as a legal warranty of properties or guarantee.

In the interest of further technical developments, we reserve the right to make design changes.

MTL4641 / MTL4641S REPEATER POWER SUPPLY

4/20mA, HART®, 2- or 3-wire transmitters

The MTL4641 provides a fully-floating dc supply for energising a conventional 2- or 3-wire 4/20mA transmitter and repeating the current in another floating circuit to drive a load. For HART 2-wire transmitters, the unit allows bi-directional communications signals superimposed on the 4/20mA loop current. Alternatively, the MTL4641S acts as a current sink rather than driving a current into the load.

SPECIFICATION

See also common specification

Number of channels

One

Output

Signal range:	4 to 20mA
Under/over-range:	0 to 24mA
Load resistance (MTL4641)	
@ 24mA:	0 to 375Ω
@ 20mA:	0 to 465Ω
Load (MTL4641S)	
Current sink:	600Ω max.
Maximum voltage source:	24V dc
Circuit output resistance:	> 1MΩ

Circuit ripple

< 50μA peak-to-peak

Input

Signal range:	0 to 24mA (including over-range)
Transmitter voltage:	20V at 20mA (MTL4641) 16.5V at 20mA (MTL4641S)

Transfer accuracy at 20°C

Better than 20μA	4-20mA (Terminals 1 & 2)
Better than 30μA	4-20mA (Terminals 1 & 3)

Temperature drift

< 0.8μA/°C

Response time

Settles to within 10% of final value within 50μs

MTL4641 / MTL4641S

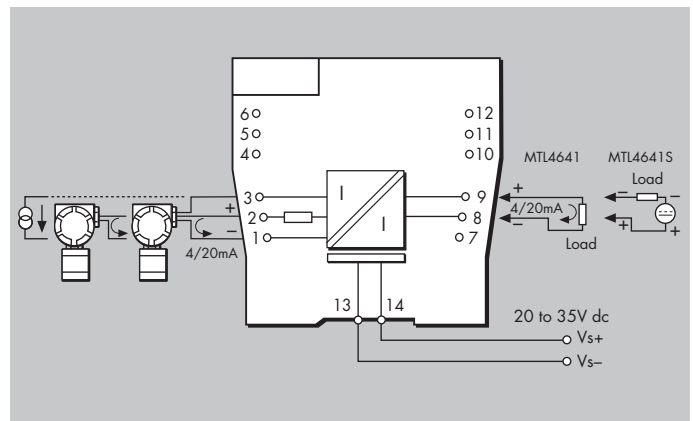

Communications supported

HART (terminals 1 & 2 only)

LED indicator

Green: power indication

Maximum current consumption (with 20mA signal)

53mA at 24V

Power dissipation within unit (with 20mA signal)

MTL4641	0.8W @ 24V dc
MTL4641S	1.0W @ 24V dc

The given data is only intended as a product description and should not be regarded as a legal warranty of properties or guarantee. In the interest of further technical developments, we reserve the right to make design changes.



Powering Business Worldwide

Eaton Electric Limited,

Great Marlings, Butterfield, Luton
Beds, LU2 8DL, UK.
Tel: + 44 (0)1582 723633 Fax: + 44 (0)1582 422283
E-mail: mtlenquiry@eaton.com
www.mtl-inst.com

© 2016 Eaton
All Rights Reserved
Publication No.
EPS4641/S Rev 5 010916

EUROPE (EMEA):

+44 (0)1582 723633 mtlenquiry@eaton.com

THE AMERICAS:

+1 800 835 7075 mtl-us-info@eaton.com

ASIA-PACIFIC:

+65 6 645 9888 sales.mtlsing@eaton.com

MTL4644A / MTL4644AS

CURRENT REPEATER

4/20mA passive i/p for HART® transmitters

The MTL4644A provides an input for separately powered 4/20mA transmitters and also allows bi-directional transmission of HART communication signals superimposed on the 4/20mA loop current, so that the transmitter can be interrogated either from the operator station or by a hand-held communicator (HHC). Alternatively, the MTL4644AS acts as a current sink rather than driving a current into the load.

SPECIFICATION

See also common specification

Number of channels

Two

Input

Signal range: 4 to 20mA
Under/over-range: 1.0 to 21.5mA

Input impedance for HART signals

at terminals 1, 2 and 4, 5: > 230Ω

Maximum input volt drop

at terminals 1, 2 and 4, 5: < 6.6V
i.e. a transmitter load of 330Ω at 20mA

Output

Signal range: 4 to 20mA
Under/over-range: 1.0 to 21.5mA
Load resistance (MTL4644A)
Conventional transmitters: 0 to 360Ω
Smart transmitters: 250Ω ±10%
Load (MTL4644AS)
Current sink: 600Ω max.
Maximum voltage source: 24V DC
Circuit output resistance: > 1MΩ

Circuit ripple

< 50μA peak-to-peak up to 80kHz

Transfer accuracy at 20°C

Better than 20μA

Temperature drift

< 1μA/°C

Response time

Settles within 200μA of final value after 20ms

Communications supported

HART

MTL4644A / MTL4644AS

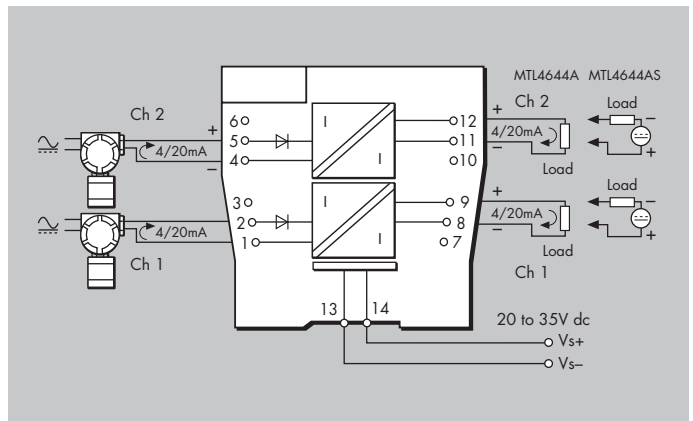

LED indicator

Green: power indication

Power requirement (with 20mA signal)

70mA at 24V
85mA at 20V
50mA at 35V

Power dissipation within unit (with 20mA signals)

MTL4644A 1.5W @ 24V dc
MTL4644AS 2.0W @ 24V dc

The given data is only intended as a product description and should not be regarded as a legal warranty of properties or guarantee. In the interest of further technical developments, we reserve the right to make design changes.



Powering Business Worldwide

Eaton Electric Limited,
Great Marlings, Butterfield, Luton
Beds, LU2 8DL, UK.
Tel: + 44 (0)1582 723633 Fax: + 44 (0)1582 422283
E-mail: mtlenquiry@eaton.com
www.mtl-inst.com

© 2016 Eaton
All Rights Reserved
Publication No.
EPS4644A/AS Rev 3 010916

EUROPE (EMEA):
+44 (0)1582 723633 mtlenquiry@eaton.com
THE AMERICAS:
+1 800 835 7075 mtl-us-info@eaton.com
ASIA-PACIFIC:
+65 6 645 9888 sales.mtlsing@eaton.com

MTL4644D REPEATER POWER SUPPLY

single channel, 4/20mA, HART®
for 2- or 3-wire transmitters, two outputs

The MTL4644D provides a fully-floating dc supply for energising a conventional 2- or 3-wire 4/20mA transmitter and repeating the current in other circuits to drive two loads. For HART 2-wire transmitters, the unit allows bi-directional transmission of digital communication signals superimposed on the 4/20mA loop current.

SPECIFICATION

See also common specification

Number of channels

One

Output

Signal range: 4 to 20mA
Under/over-range: 0 to 24mA
Load resistance
@ 24mA: 0 to 360Ω
@ 20mA: 0 to 450Ω
Circuit output resistance: > 1MΩ

Circuit ripple

< 50μA peak-to-peak

Input

Signal range: 0 to 24mA (including over-range)
Transmitter voltage: 16.5V at 20mA

Transfer accuracy at 20°C

Better than 15μA

Temperature drift

< 0.8μA/°C

Response time

Settles to within 10% of final value within 50μs

Communications supported

HART (terminals 1 & 2, output Ch 1 only)

MTL4644D

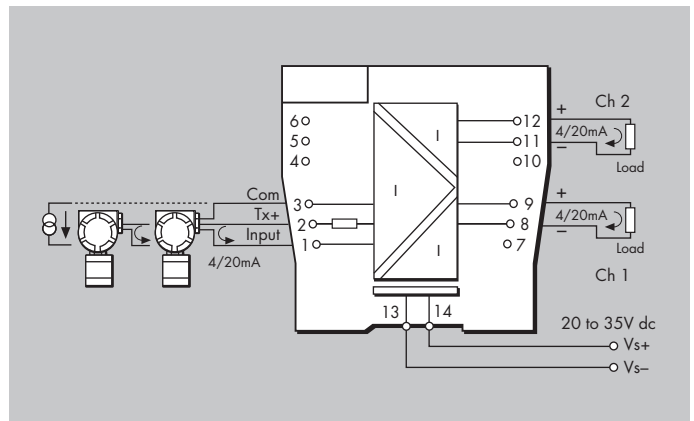

LED indicator

Green: power indication

Maximum current consumption (with 20mA signals)

96mA at 24V dc

Power dissipation within unit (with 20mA signals)

1.4W @ 24V dc



Powering Business Worldwide

Eaton Electric Limited,

Great Marlings, Butterfield, Luton
Beds, LU2 8DL, UK.
Tel: + 44 (0)1582 723633 Fax: + 44 (0)1582 422283
E-mail: mtlenquiry@eaton.com
www.mtl-inst.com

© 2016 Eaton
All Rights Reserved
Publication No.
EPS4644D Rev 3 010916

EUROPE (EMEA):

+44 (0)1582 723633 mtlenquiry@eaton.com

THE AMERICAS:

+1 800 835 7075 mtl-us-info@eaton.com

ASIA-PACIFIC:

+65 6 645 9888 sales.mtlsing@eaton.com

The given data is only intended as a product description and should not be regarded as a legal warranty of properties or guarantee.
In the interest of further technical developments, we reserve the right to make design changes.

MTL4644 / MTL4644S

REPEATER POWER SUPPLY

2-channel, 4/20mA, HART®, 2- or 3- wire transmitters

The MTL4644 provides fully-floating dc supplies for energising two conventional 2-wire or 3-wire 4/20mA or HART transmitters, and repeats the current in other circuits to drive two loads. For smart transmitters, the unit allows bi-directional transmission of digital communication signals superimposed on the 4/20mA loop current. Alternatively, the MTL4644S acts as a current sink rather than driving a current into the load.

SPECIFICATION

See also common specification

Number of channels

Two

Output

Signal range:	4 to 20mA
Under/over-range:	0 to 24mA
Load resistance (MTL4644)	
@ 24mA:	0 to 375Ω
@ 20mA:	0 to 465Ω
Load (MTL4644S)	
Current sink:	600Ω max.
Maximum voltage source:	24V dc
Circuit output resistance:	> 1MΩ

Circuit ripple

< 50µA peak-to-peak

Input

Signal range:	0 to 24mA (including over-range)
Transmitter voltage:	20V at 20mA

Transfer accuracy at 20°C

Better than 20µA 4-20mA (Terminals 1 & 2 / 4 & 5)
Better than 30µA 4-20mA (Terminals 1 & 3 / 4 & 6)

Temperature drift

< 0.8µA/°C

Response time

Settles to within 10% of final value within 50µs

MTL4644 / MTL4644S

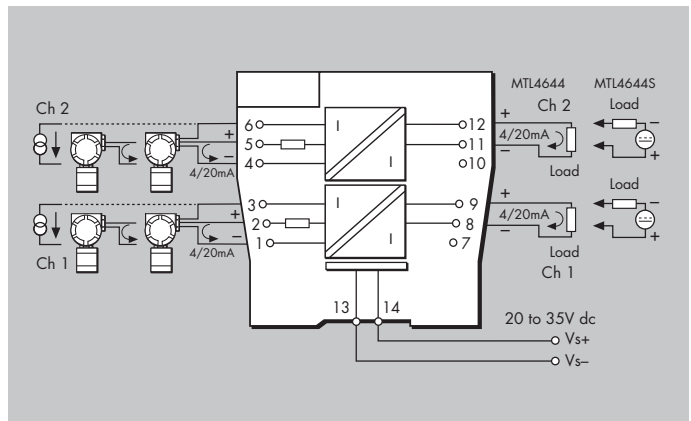

Communications supported

HART (terminals 1 & 2 and 4 & 5 only)

LED indicator

Green: power indication

Maximum current consumption (with 20mA signals)

100mA at 24V dc

Power dissipation within unit (with 20mA signals)

MTL4644	1.5W @ 24V dc
MTL4644S	2.0W @ 24V dc

The given data is only intended as a product description and should not be regarded as a legal warranty of properties or guarantee. In the interest of further technical developments, we reserve the right to make design changes.



Powering Business Worldwide

Eaton Electric Limited,

Great Marlings, Butterfield, Luton
Beds, LU2 8DL, UK.
Tel: + 44 (0)1582 723633 Fax: + 44 (0)1582 422283
E-mail: mtlenquiry@eaton.com
www.mtl-inst.com

© 2016 Eaton
All Rights Reserved
Publication No.
EPS4644/S Rev 4 010916

EUROPE (EMEA):

+44 (0)1582 723633 mtlenquiry@eaton.com

THE AMERICAS:

+1 800 835 7075 mtl-us-info@eaton.com

ASIA-PACIFIC:

+65 6 645 9888 sales.mtlsing@eaton.com

MTL4646 / MTL4646Y

ISOLATING DRIVER

for 4–20mA HART® valve positioners with line fault detection

The MTL4646 accepts a 4/20mA floating signal from a safe-area controller to drive a current/pressure converter (or any other load up to 800Ω). For HART valve positioners, the module also permits bi-directional transmission of digital communication signals. Process controllers with a readback facility can detect open or short circuits in the field wiring: if these occur, the current taken into the terminals drops to a preset level. The MTL4646Y is very similar except that it provides open circuit detection only (i.e. no short-circuit detection).

SPECIFICATION

See also common specification

Number of channels

One

Working range

4 to 20mA

Digital signal bandwidth

500Hz to 10kHz

Maximum load resistance

800Ω (16V at 20mA)

Minimum load resistance

90Ω (short-circuit detection at < 50Ω)

Output resistance

> 1MΩ

Under/over range capability

Under range = 1mA

Over range = 24mA (load ≤ 520Ω)

Input and output circuit ripple

< 40μA peak-to-peak

Transfer accuracy at 20°C

Better than 20μA

Temperature drift

< 1.0μA/°C

Input characteristics

Field wiring state	MTL4646	MTL4646Y
Normal	< 6.0V	< 6.0V
Open-circuit	< 0.9mA	< 0.5mA
Short-circuit	< 0.9mA	N.A.

MTL4646 / MTL4646Y

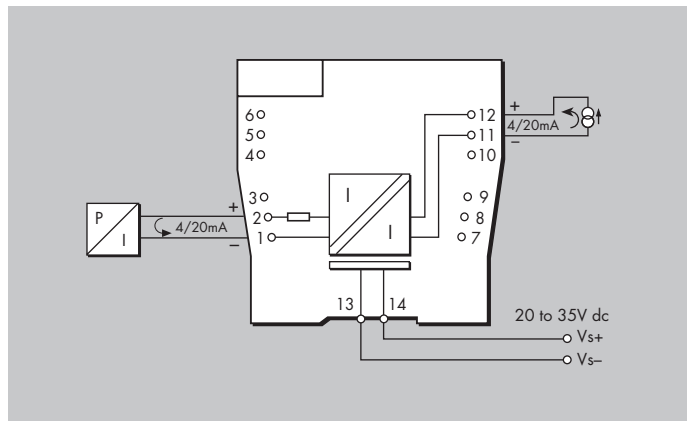

Response time

Settles within 200μA of final value within 100ms

Communications supported

HART

LED indicator

Green: power indication

Maximum current consumption (with 20mA signals into 250Ω load)

35mA at 24V dc

Power dissipation within unit (with 20mA signals into 250Ω load)

0.8W at 24V



Powering Business Worldwide

Eaton Electric Limited,

Great Marlings, Butterfield, Luton
Beds, LU2 8DL, UK.
Tel: + 44 (0)1582 723633 Fax: + 44 (0)1582 422283
E-mail: mtlenquiry@eaton.com
www.mtl-inst.com

© 2016 Eaton
All Rights Reserved
Publication No.
EPS4646/Y Rev 3 010916

EUROPE (EMEA):

+44 (0)1582 723633 mtlenquiry@eaton.com

THE AMERICAS:

+1 800 835 7075 mtl-us-info@eaton.com

ASIA-PACIFIC:

+65 6 645 9888 sales.mtlsing@eaton.com

The given data is only intended as a product description and should not be regarded as a legal warranty of properties or guarantee.
In the interest of further technical developments, we reserve the right to make design changes.

MTL4649 / MTL4649Y

ISOLATING DRIVER

two-channel, for 4–20mA, HART®
valve positioners with line fault detection

The MTL4649 accepts 4/20mA floating signals from a controller to drive 2 current/pressure converters (or any other load up to 800Ω). For HART valve positioners, the module also permits bi-directional transmission of digital communication signals. Process controllers with a readback facility can detect open or short circuits in the field wiring: if these occur, the current taken into the terminals drops to a preset level. The MTL4649Y is very similar except that it provides open circuit detection only (i.e. no short-circuit detection).

SPECIFICATION

See also common specification

Number of channels

Two

Working range

4 to 20mA

Digital signal bandwidth

500Hz to 10kHz

Maximum load resistance

800Ω (16V at 20mA)

Minimum load resistance

90Ω (short-circuit detection at < 50Ω)

Output resistance

> 1MΩ

Under/over range capability

Under range = 1mA

Over range = 24mA (load ≤ 520Ω)

Input and output circuit ripple

<40μA peak-to-peak

Communications supported

HART

Transfer accuracy at 20°C

Better than 20μA

Temperature drift

< 1.0μA/°C

Input characteristics

Field wiring state	MTL4649	MTL4649Y
Normal	< 6.0V	< 6.0V
Open-circuit	< 0.9mA	< 0.5mA
Short-circuit	< 0.9mA	N.A.

MTL4649 / MTL4649Y

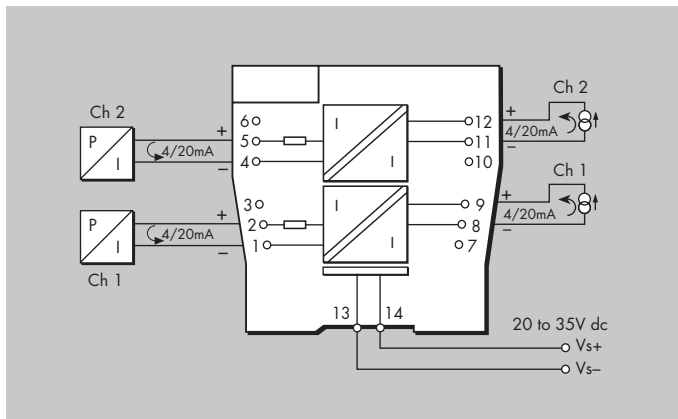

Response time

Settles within 200μA of final value within 100ms

LED indicator

Green: power indication

Maximum current consumption (with 20mA signals into 250Ω load)

70mA at 24V dc

Power dissipation within unit (with 20mA signals into 250Ω load)

1.6W at 24V

The given data is only intended as a product description and should not be regarded as a legal warranty of properties or guarantee. In the interest of further technical developments, we reserve the right to make design changes.



Powering Business Worldwide

Eaton Electric Limited,

Great Marlings, Butterfield, Luton
Beds, LU2 8DL, UK.
Tel: + 44 (0)1582 723633 Fax: + 44 (0)1582 422283
E-mail: mtlenquiry@eaton.com
www.mtl-inst.com

© 2016 Eaton
All Rights Reserved
Publication No.
EPS4649/Y Rev 3 010916

EUROPE (EMEA):

+44 (0)1582 723633 mtlenquiry@eaton.com

THE AMERICAS:

+1 800 835 7075 mtl-us-info@eaton.com

ASIA-PACIFIC:

+65 6 645 9888 sales.mtlsing@eaton.com

MTL4675

TEMPERATURE CONVERTER

THC or RTD input + Alarm

The MTL4675 converts a low-level dc signal from a temperature sensor mounted into a 4/20mA current for driving a load. Software selectable features include linearisation, ranging, monitoring, testing and tagging for all thermocouple types and 2-, 3- or 4-wire RTDs. (For thermocouple applications the SAF-CJC plug on terminals 1–3 includes an integral CJC sensor). Configuration is carried out using a personal computer. A single alarm output is provided and may be configured for high or low process alarm or to provide notice of early thermocouple failure.

SPECIFICATION

See also common specification

Number of channels

One

Signal source

THC types J, K, T, E, R, S, B or N to BS 60584 and XK
mV input
RTDs 2/3/4-wire platinum to BS 60751
Pt 100, Pt 500, Pt 1000
Cu-50 & Cu-53
Ni 100/500/1000 DIN 43760

Input signal range

–75 to +75mV, or 0 to 400Ω (0 to 1000Ω Pt & Ni sensors)

Input signal span

3 to 150mV, or 10 to 400Ω (10 to 1000Ω Pt & Ni sensors)

RTD excitation current

200μA nominal

Cold junction compensation

Automatic or selectable

Cold junction compensation error

≤ 1.0°C

Common mode rejection

120dB for 240V at 50Hz or 60Hz (500ms response)

Series mode rejection

40dB for 50Hz or 60Hz

Calibration accuracy (at 20°C)

(includes hysteresis, non-linearity and repeatability)

Inputs: (500ms response)

mV/THC: ± 15μV or ± 0.05% of input value
(whichever is greater)
RTD: ± 80mΩ
Output: ± 11μA

Temperature drift (typical)

Inputs:

mV/THC: ± 0.003% of input value/°C
RTD: ± 7mΩ/°C
Output: ± 0.6μA/°C

Example of calibration accuracy and temperature drift (RTD input - 500ms response)

Span: 250Ω
Accuracy: ± (0.08/250 + 11/16000) × 100%
= 0.1% of span
Temperature drift: ± (0.007/250 × 16000 + 0.6) μA/°C
= ±1.0μA/°C

Safety drive on sensor failure

Upscale, downscale, or off

Early burnout

Early burnout detection for thermocouples (when selected)
Alarm trips when loop resistance increase is > 50Ω

MTL4675

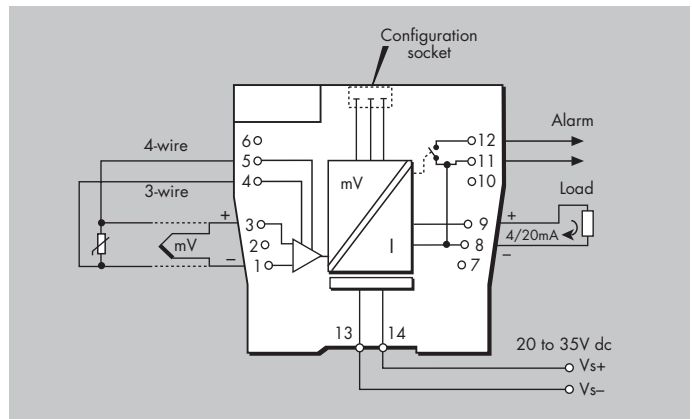

Output range

4 to 20mA nominal into 600Ω max. (direct or reverse)

Alarm output (configurable)

Relay ON in alarm, 250mA @ 35V max

Maximum lead resistance (THC)

600Ω

Response time

Configurable - 500 ms default
(Accuracy at 100/200ms - contact MTL)

LED indicator

Green: power and status indication
Yellow: alarm indication, on when contacts are closed

Maximum current consumption (with 20mA signal)

50mA at 24V

Power dissipation within unit (with 20mA signal)

1.2W at 24V

Configurator

A personal computer running MTL PCS45 software with a PCL45USB serial interface.

The given data is only intended as a product description and should not be regarded as a legal warranty of properties or guarantee. In the interest of further technical developments, we reserve the right to make design changes.



Powering Business Worldwide

Eaton Electric Limited,
Great Marlings, Butterfield, Luton
Beds, LU2 8DL, UK.
Tel: + 44 (0)1582 723633 Fax: + 44 (0)1582 422283
E-mail: mtlenquiry@eaton.com
www.mtl-inst.com

© 2016 Eaton
All Rights Reserved
Publication No.
EPS4675 Rev 2 010916

EUROPE (EMEA):
+44 (0)1582 723633 mtlenquiry@eaton.com
THE AMERICAS:
+1 800 835 7075 mtl-us-info@eaton.com
ASIA-PACIFIC:
+65 6 645 9888 sales.mtlsing@eaton.com

MTL4676-RTD

TEMPERATURE CONVERTER

RTD/potentiometer input, 2-channel

The MTL4676-RTD converts signals from resistance temperature detectors (RTDs) into 4/20mA currents. Software selectable features include input type and characterisation, ranging, monitoring, testing and tagging. Configuration is carried out using a personal computer. The MTL4676-RTD is compatible with 2- and 3-wire RTD inputs.

SPECIFICATION

See also common specification

Number of channels

Two

Signal source

2-/3-wire RTDs to BS 60751
Pt 100, Pt 500, Pt 1000
Cu-50 & Cu-53
Ni 100/500/1000 DIN 43760

Input signal range

0 to 400Ω (0 to 4000Ω Pt & Ni sensors)

Input signal span

10 to 400Ω (10 to 1000Ω Pt & Ni sensors)

RTD excitation current

200μA nominal

Common mode rejection

120dB for 240V at 50Hz or 60Hz

Series mode rejection

40dB for 50Hz or 60Hz

Calibration accuracy (at 20°C)

(includes hysteresis, non-linearity and repeatability)

Input: ± 80mΩ

Output: ± 16μA

Temperature drift (typical)

Input: ± 7mΩ/°C

Output: ± 0.6μA/°C

Example of calibration accuracy and temperature drift

(RTD input)

Span: 250Ω

Accuracy: ± (0.08/250 + 16/16000) x 100%
= 0.13% of span

Temperature drift: ± (0.007/250 x 16000 + 0.6) μA/°C
= ±1.0μA/°C

Safety drive on sensor failure

Upscale, downscale, or off

Output range

4 to 20mA nominal into 300Ω max. (direct or reverse)

Response time

Configurable - 500 ms default

(Accuracy at 100/200ms - contact MTL)

MTL4676-RTD

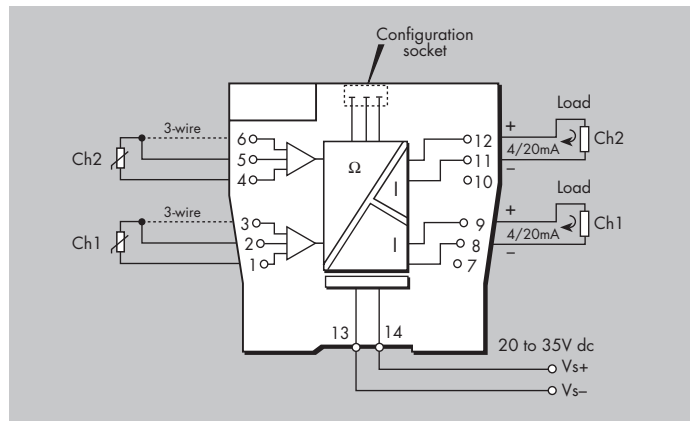

LED indicator

Green: power and status indication

Yellow: one provided for channel status

Red: alarm indication

Power requirement, Vs with 20mA signal

60mA at 24V

Power dissipation within unit with 20mA signal

1.4W at 24V

Isolation

Functional channel-channel isolation for safe and hazardous-area circuits

Configurator

A personal computer running MTL PCS45 software with a PCL45USB serial interface.



Powering Business Worldwide

Eaton Electric Limited,

Great Marlings, Butterfield, Luton
Beds, LU2 8DL, UK.
Tel: + 44 (0)1582 723633 Fax: + 44 (0)1582 422283
E-mail: mtlenquiry@eaton.com
www.mtl-inst.com

© 2016 Eaton
All Rights Reserved
Publication No.
EPS4676-R Rev 2 010916

EUROPE (EMEA):

+44 (0)1582 723633 mtlenquiry@eaton.com

THE AMERICAS:

+1 800 835 7075 mtl-us-info@eaton.com

ASIA-PACIFIC:

+65 6 645 9888 sales.mtlsing@eaton.com

The given data is only intended as a product description and should not be regarded as a legal warranty of properties or guarantee. In the interest of further technical developments, we reserve the right to make design changes.

MTL4676-THC

TEMPERATURE CONVERTER

mV/THC input, 2-channel

The MTL4676-THC converts low-level dc signals from temperature sensors mounted in a hazardous-area into 4/20mA currents. Software selectable features include linearisation for standard thermocouple types, ranging, monitoring, testing and tagging. Configuration is carried out using a personal computer. The field connections include cold-junction compensation and do not need to be ordered separately.

SPECIFICATION

See also common specification

Number of channels

Two

Signal source

THC types J, K, T, E, R, S, B or N to BS 60584 and XK mV input

Input signal range

-75 to +75mV

Input signal span

3 to 150mV

Cold junction compensation

Automatic or selectable

Cold junction compensation error

≤ 1.0°C

Common mode rejection

120dB for 240V at 50Hz or 60Hz

Series mode rejection

40dB for 50Hz or 60Hz

Calibration accuracy (at 20°C)

(includes hysteresis, non-linearity and repeatability)

Input: ±15µV or ±0.05% of input value (whichever is greater)

Output: ±16µA

Temperature drift (typical)

Input: ±0.003% of input value/°C

Output: ±0.6µA/°C

Safety drive on sensor burnout

Upscale, downscale, or off

Output range

4 to 20mA nominal into 300Ω max. (direct or reverse)

Maximum lead resistance

300Ω

Response time

Configurable - 500 ms default

(Accuracy at 100/200ms - contact MTL)

MTL4676-THC

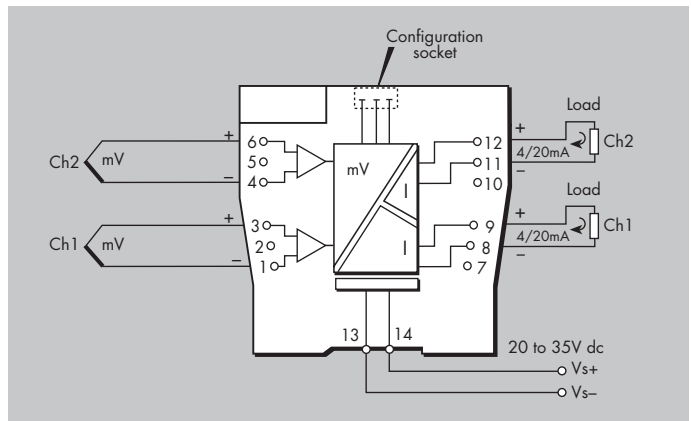

LED indicator

Green: power and status indication

Yellow: one provided for channel status

Red: alarm indication

Power requirement, Vs with 20mA signal

60mA at 24V

Power dissipation within unit with 20mA signal

1.4W at 24V

Isolation

Functional isolation channel-channel for input and output circuits.

Configurator

A personal computer running MTL PCS45 software with a PCL45USB serial interface.

The given data is only intended as a product description and should not be regarded as a legal warranty of properties or guarantee. In the interest of further technical developments, we reserve the right to make design changes.



Powering Business Worldwide

Eaton Electric Limited,

Great Marlings, Butterfield, Luton
Beds, LU2 8DL, UK.
Tel: + 44 (0)1582 723633 Fax: + 44 (0)1582 422283
E-mail: mtlenquiry@eaton.com
www.mtl-inst.com

© 2016 Eaton
All Rights Reserved
Publication No.
EPS4676T Rev 2 010916

EUROPE (EMEA):

+44 (0)1582 723633 mtlenquiry@eaton.com

THE AMERICAS:

+1 800 835 7075 mtl-us-info@eaton.com

ASIA-PACIFIC:

+65 6 645 9888 sales.mtlsing@eaton.com

MTL4600 RANGE COMMON SPECIFICATIONS

DIMENSIONS (MM)

MTL4600

Optional TH5000 tag holder for individual isolator identification.
Accepts tag label 25 x 12.5 ±0.5mm, 0.2mm thick

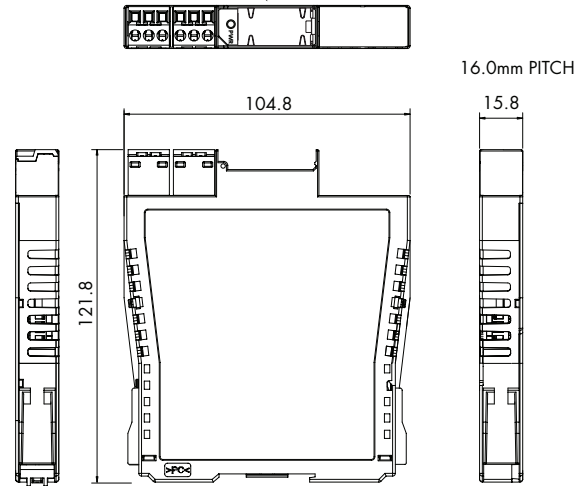

Please go to our website at www.mtl-inst.com for the latest information regarding safety approvals, certificates and entity parameters.

Connectors

Each unit is supplied with signal connectors, as applicable.
When using crimp ferrules for the signal connectors the metal tube length should be 12mm and the wire trim length 14mm.

Isolation

1500V rms minimum, between system and field terminals.
50V between system circuits and power supply

Supply voltage

20 – 35V dc

Terminals

Accepts conductors of up to 2.5mm² stranded or single-core

Mounting

MTL4500/4600 series backplanes

Ambient temperature limits

-20 to +60°C (-6 to +140°F) operating
-40 to +80°C (-40 to +176°F) storage

Humidity

5 to 95% relative humidity

Weight

140g

Approximate (except where indicated)

HART® is a registered trademark of HART Communication Foundation



Powering Business Worldwide

Eaton Electric Limited,

Great Marlings, Butterfield, Luton
Beds, LU2 8DL, UK.
Tel: + 44 (0)1582 723633 Fax: + 44 (0)1582 422283
E-mail: mtlenquiry@eaton.com
www.mtl-inst.com

© 2016 Eaton
All Rights Reserved
Publication No.
EPS46CS Rev 2 010916

EUROPE (EMEA):

+44 (0)1582 723633 mtlenquiry@eaton.com

THE AMERICAS:

+1 800 835 7075 mtl-us-info@eaton.com

ASIA-PACIFIC:

+65 6 645 9888 sales.mtlsing@eaton.com

The given data is only intended as a product description and should not be regarded as a legal warranty of properties or guarantee.
In the interest of further technical developments, we reserve the right to make design changes.

PCS45/PCL45USB CONFIGURATOR FOR MTL CONVERTERS

The PCS45/PCL45USB configurator allows MTL converters to be configured from a standard PC running a Microsoft® Windows® operating system. It comprises PC software, provided on a CD (PCS45), and an ATEX certified interfacing link (PCL45USB). Converters can be configured from the safe area, while on-line, and configurations can be saved to disk and printed out when required. It is suitable for use with MTL4000, MTL4500, MTL4600, MTL5000 and MTL5500 range of products.

SPECIFICATION

PCL45USB hardware

Location

Safe area

Connections

PC side: USB B(F) socket

Converter side: cable with 3.5mm jackplug, 3-pole for MTL4500, MTL4600 and MTL5500 range of converters. An adapter cable is provided for other earlier MTL converters.

Cable lengths

Converter side (fitted): 1.5m

USB cable A(M) to B(M) (supplied): 2m

Ambient temperature limits

-10°C to +60°C operating

-20°C to +70°C storage

Humidity

5 to 95% relative humidity (non-condensing)

Weight

200g

PCS45 Configuration software

Compatible with Windows 2000 or Windows XP.

Consult MTL for operation with any other operating system, e.g. Windows Vista™.

Software medium

PCS45 supplied on CD

Updates are available at www.mtl-inst.com

Recommended minimum PC configuration

Microsoft Windows 2000 or Windows XP

20MB of available hard disc space

CD ROM drive

Available USB port

Printer (local or network)

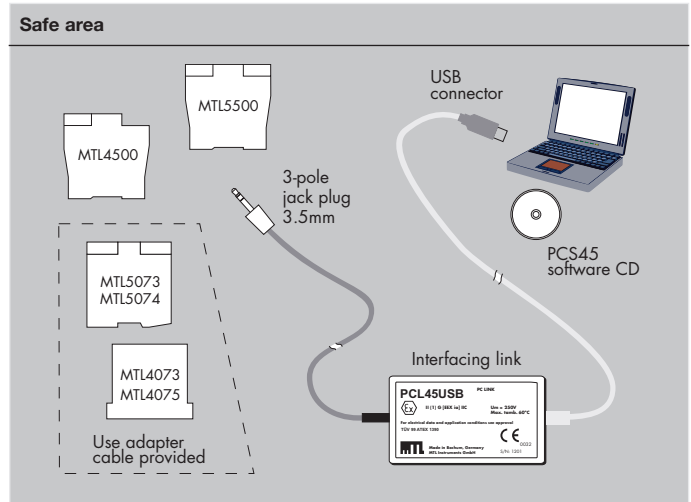

The given data is only intended as a product description and should not be regarded as a legal warranty of properties or guarantee. In the interest of further technical developments, we reserve the right to make design changes.



Powering Business Worldwide

Eaton Electric Limited,

Great Marlings, Butterfield, Luton Beds, LU2 8DL, UK.

Tel: + 44 (0)1582 723633 Fax: + 44 (0)1582 422283

E-mail: mtl enquiry@eaton.com

www.mtl-inst.com

© 2016 Eaton

All Rights Reserved

Publication No.

EPS4600 Rev 2 010916

EUROPE (EMEA):

+44 (0)1582 723633 mtl enquiry@eaton.com

THE AMERICAS:

+1 800 835 7075 mtl-us-info@eaton.com

ASIA-PACIFIC:

+65 6 645 9888 sales.mtl sing@eaton.com

CUSTOM, STANDARD AND UNIVERSAL BACKPLANES FOR EASY DCS INTEGRATION

- Total flexibility
- Reduce wiring
- Simplify installation
- Special functions
- Signal conditioning
- HART® integration

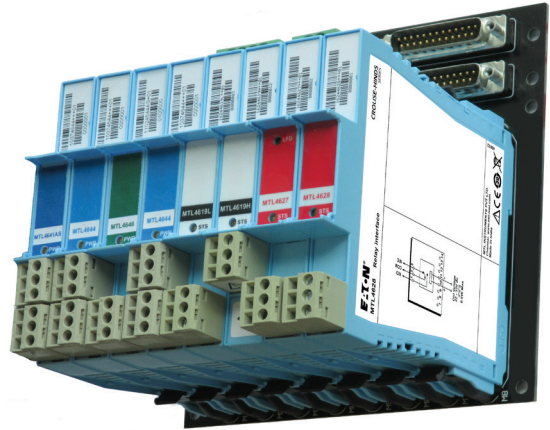

The MTL4500/MTL4600 range of backplanes, enclosures and other accessories provide comprehensive, flexible and remarkably compact mounting facilities for system vendors, original equipment manufacturers and end users alike.

CUSTOMISED BACKPLANES

Eaton provides a complete design and manufacturing service for MTL customised backplanes. Customised backplanes give the vendors and users of process control and safety systems the opportunity to integrate MTL4500/MTL4600/HART® modules directly into their system architecture. As there are no hazardous-area circuits on the backplanes, customised versions can be produced without the need for IS certification, so simplifying design and lowering costs.

UNIVERSAL CUSTOM BACKPLANES

The 'universal' backplane allows a fast and economic approach to providing a custom interface. Where tight time schedules exist, the backplane can be installed to allow the panel building and wiring to be completed. The customised adapter card can then be plugged in at any time up to integrated test.

ADAPTER CARDS

Adapter cards already exist for many of the DCS companies. In addition there is a range of general purpose cards that offer reduced wiring for use with specific MTL modules. These are also available in left- and right-hand versions to ease panel wiring.

STANDARD MTL BACKPLANES

Standard MTL backplanes are available to accommodate 4, 8, 16, or 24 modules using screw-clamp connectors for the safe-area circuits. On an individual backplane, any module can be plugged into any position and module types can be mixed. For 8-, 16- and 24-way backplanes, screw-clamp connectors which plug into the backplanes provide primary and secondary 24V dc power supplies. Power to several 8- or 16-way backplanes can be interconnected to reduce and simplify wiring – see instruction manual INM4500/INM4600 for details.

MTL CPS STANDARD BACKPLANES

Backplane model no.	Number of modules	Safe-area connections	MOUNTING KITS			ACCESSORIES		
			Surface	DIN-rail (T or G)	19-inch rack	Earth-rail kit	Tagging strip kit	Spare fuse pack
CPS04	4	Screw-clamp	SMS01	DMK01	–	–	–	FUS1.0ATE5
CPS08	8	Screw-clamp	SMS01	DMK01	–	ERK08	TSK08	FUS1.0ATE5
CPS16	16	Screw-clamp	SMS01	DMK01	–	ERK16	TSK16	FUS2.0ATE5 or FUS2.5ATE5
CPS24	24	Screw-clamp	SMS01	DMK01	HMP24	–	TSK24	FUS4.0ATE5

OPTIONAL ACCESSORIES

Optional accessories include colour coded tagging strip kits for all three sizes of backplane and earth rail kits for 8 and 16-way versions. Mounting accessories are available for surface (all backplanes), T-section and G-section DIN-rail (8- and 16-way versions), and a horizontal plate for mounting 24-way backplanes in 19-inch racks.

WEATHERPROOF ENCLOSURES

Weatherproof enclosures are available for applications where separate safe-area enclosures are required for backplanes with modules. Available to accommodate one 4-way or one 8-way backplane, they are manufactured from GRP giving protection against dust and water to IEC529:IP65. The lids are made from transparent high-strength polycarbonate so that LEDs, switches, etc, on the tops of the modules are easy to see.

DCS VENDORS/SYSTEMS SUPPORTED:

ABB Automation

S100, INFI90, S800

Emerson

Delta V, M Series, S Series

GE Bently-Nevada

HIMA

HIMax

Honeywell

PMIO, C200, C300, UPIO, Safety Manager, USIO

Rockwell Automation

ICS Triplex, Plantguard

Schneider Electric

Foxboro I/A, Triconex Trident/Tricon, Modicon

Siemens

ET200, S7

Yokogawa

Centum R3, VP, Prosafe RS, CS3000

The given data is only intended as a product description and should not be regarded as a legal warranty of properties or guarantee. In the interest of further technical developments, we reserve the right to make design changes.



Powering Business Worldwide

Eaton Electric Limited,

Great Marlings, Butterfield, Luton Beds, LU2 8DL, UK.
Tel: + 44 (0)1582 723633 Fax: + 44 (0)1582 422283
E-mail: mtlenquiry@eaton.com
www.mtl-inst.com

© 2016 Eaton
All Rights Reserved
Publication No.
EPS45-46 backplane Rev 6
010916

EUROPE (EMEA):

+44 (0)1582 723633 mtlenquiry@eaton.com

THE AMERICAS:

+1 800 835 7075 mtl-us-info@eaton.com

ASIA-PACIFIC:

+65 6 645 9888 sales.mtlsing@eaton.com

CPS BACKPLANE DIMENSIONS (mm)

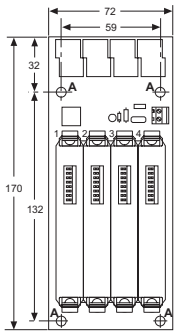

CPS04
CPS04-CC

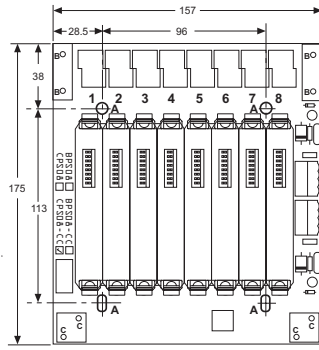

CPS08
CPS08-CC

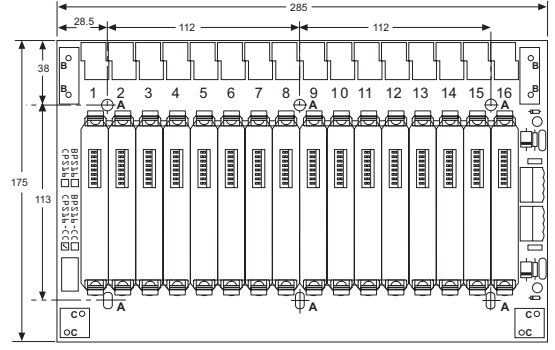

CPS16
CPS16-CC

-CC - Conformal Coating

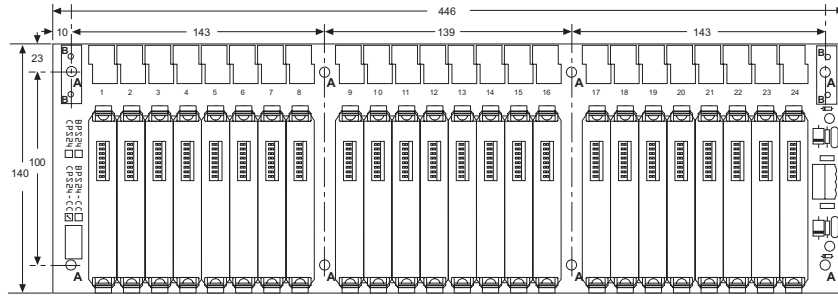

CPS24

Power requirements, Vs

21V dc to 35V dc through plug-in connectors

Safe-area connections

CPS: 2.5mm² screw-clamp terminals – 6 positions per module

Weight (without modules or accessories)

CPS04:	96g
CPS08:	225g
CPS16:	419g
CPS24:	592g

HMP24 - 19" RACK MOUNTING PLATE FOR CPS24

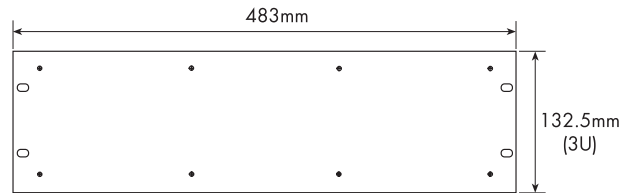

BACKPLANE ACCESSORIES

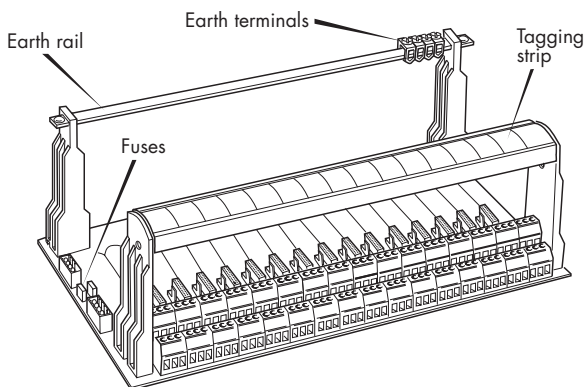

SCK45 - backplane clips



10 x strip of four

MCK45 - backplane clips



16 x strip of two



Powering Business Worldwide

Eaton Electric Limited,
Great Marlings, Butterfield, Luton
Beds, LU2 8DL, UK.
Tel: + 44 (0)1582 723633 Fax: + 44 (0)1582 422283
E-mail: mtl-enquiry@eaton.com
www.mtl-inst.com

© 2016 Eaton
All Rights Reserved
Publication No.
EPS45-46 backplane Rev 6
010916

EUROPE (EMEA):
+44 (0)1582 723633 mtl-enquiry@eaton.com
THE AMERICAS:
+1 800 835 7075 mtl-us-info@eaton.com
ASIA-PACIFIC:
+65 6 645 9888 sales.mtlsing@eaton.com

ORDERING INFORMATION



MTL4600 range of isolators

Specify part number: eg, **MTL4611**

Individual isolator identification

TH5000 Tag holder (Pack of 20)

Connectors - MTL4600

SAF-CJC Field plug, terminals 1 and 3 with cold-junction sensor

SAF-CJC2 Field plug, terminals 4 and 6 with cold-junction sensor

SAF1-3 System plug, terminals 1, 2 and 3

SAF4-6 System plug, terminals 4, 5 and 6



MTL4500/4600 Standard Backplanes

CPS04 4-way backplane screw-clamp connector

CPS08 8-way backplane screw-clamp connector

CPS16 16-way backplane screw-clamp connector

CPS24 24-way backplane screw-clamp connector

MTL4500/4600 Custom Backplanes

Contact MTL for options and advice



MTL4500/4600 Backplane mounting accessories

DMK01 DIN-rail mounting kit, T- or G-section (pack of 40)

8-way backplanes require 4,
16-way backplanes require 6

SMS01 Surface mounting kit (pack of 40)
4- and 8-way backplanes require 4,
16-way backplanes require 6,
24-way backplanes require 8

HMP24 Horizontal mounting plate and screws for 19-inch rack mounting
24-way backplanes only

BMK08 Mounting kit for one 4- or 8-way backplane

BMK16 Mounting kit for one 16-way backplane

MTL4600 Backplane accessories

ERK08 Earth rail kit for CPS08 backplane

ERK16 Earth rail kit for CPS16 backplane

TSK08 Tagging strip kit for CPS08 backplane

TSK16 Tagging strip kit for CPS16 backplane

TSK24 Tagging strip kit for CPS24 backplane

FUS1.0ATE5 Fuse kit for 4- and 8-way backplanes, (10 per pack)

FUS2.0ATE5 Fuse kit for 16-way backplane, (10 per pack)

FUS4.0ATE5 Fuse kit for 24-way backplanes, (10 per pack)

MCK45 MTL4000 backplane conversion kit (16 clip pairs per pack)

SCK45 Module 4-clip strips (10 strips + 40 rivets per pack)

MPL01 Module position label (blank) (50 per pack)



Literature

INM4500 MTL4600 range instruction manual

Configurator and software

PCL45USB Configurator, PC interface and software

PCS45 PC software

Please go to our website at www.mtl-inst.com for the latest information.



Powering Business Worldwide

Eaton Electric Limited,
Great Marlings, Butterfield, Luton
Beds, LU2 8DL, UK.
Tel: + 44 (0)1582 723633 Fax: + 44 (0)1582 422283
E-mail: mtlenquiry@eaton.com
www.mtl-inst.com

© 2016 Eaton
All Rights Reserved
Publication No.
EPS4600_ORD Rev 2 01091

EUROPE (EMEA):
+44 (0)1582 723633 mtlenquiry@eaton.com
THE AMERICAS:
+1 800 835 7075 mtl-us-info@eaton.com
ASIA-PACIFIC:
+65 6 645 9888 sales.mtlsing@eaton.com